

Description

Introduction

The Watt transducer (PWT) is an ac power transducer that accurately measures the electric power consumed in equipment or systems where remote indication and/or automatic control functions are required. This highly accurate electronic multiplying device has excellent long term stability and maintainability.

Installation

Mechanical Installation

The PWT is enclosed in an extruded aluminum housing. The mounting plate features keyhole cutouts so that the entire housing can be removed by just loosening the screws. See the Surface Mount (SM) housing sheet for a physical outline and mechanical installation requirements.

Electrical Installation

All electrical connections are made to the terminal block on the front of the unit. See figures 1-6.

External Power. If the unit is powered externally, connect 120Vac to the terminals marked EXT PWR. Internally powered units have the electronics power supply fed from the potential transformer connections at terminals 3 and 4.

Voltage (potential). All voltage connections are to the internal transformer terminations, which are balanced and isolated from each other. If the proper voltages are present and in the correct phase, either side of any voltage input may be commoned and/or connected to ground.

Current. Current inputs require security because an open circuit in the current transformer is hazardous. It is recommended that ring lugs be used for all connections. When used with binding head screws, these lugs provide a secure vibration-proof connection.

Figures 1-6 show the transducer connected in an instrumentation loop. The inputs are balanced and isolated from each other. Either side may be commoned and or grounded.

Output. Constant current outputs do not react to resistance changes in the wire, so no calibration is required to compensate for lead length. If a voltage input is required by the measuring or telemetry equipment, a precision resistor may be placed at the measuring end to create a voltage from the constant current.

The constant current loops are not as susceptible to noise and transients as voltage outputs, but should be protected by using shielded wire if the cable runs exceeds 65 feet. Outputs from several transducers can be run in one common shield. The shield should be firmly grounded at ONE end ONLY.

Constant voltage outputs require special handling considerations because a voltage drop in the wire can affect the reading. High input impedance measuring equipment is required and shielded wire is mandatory.

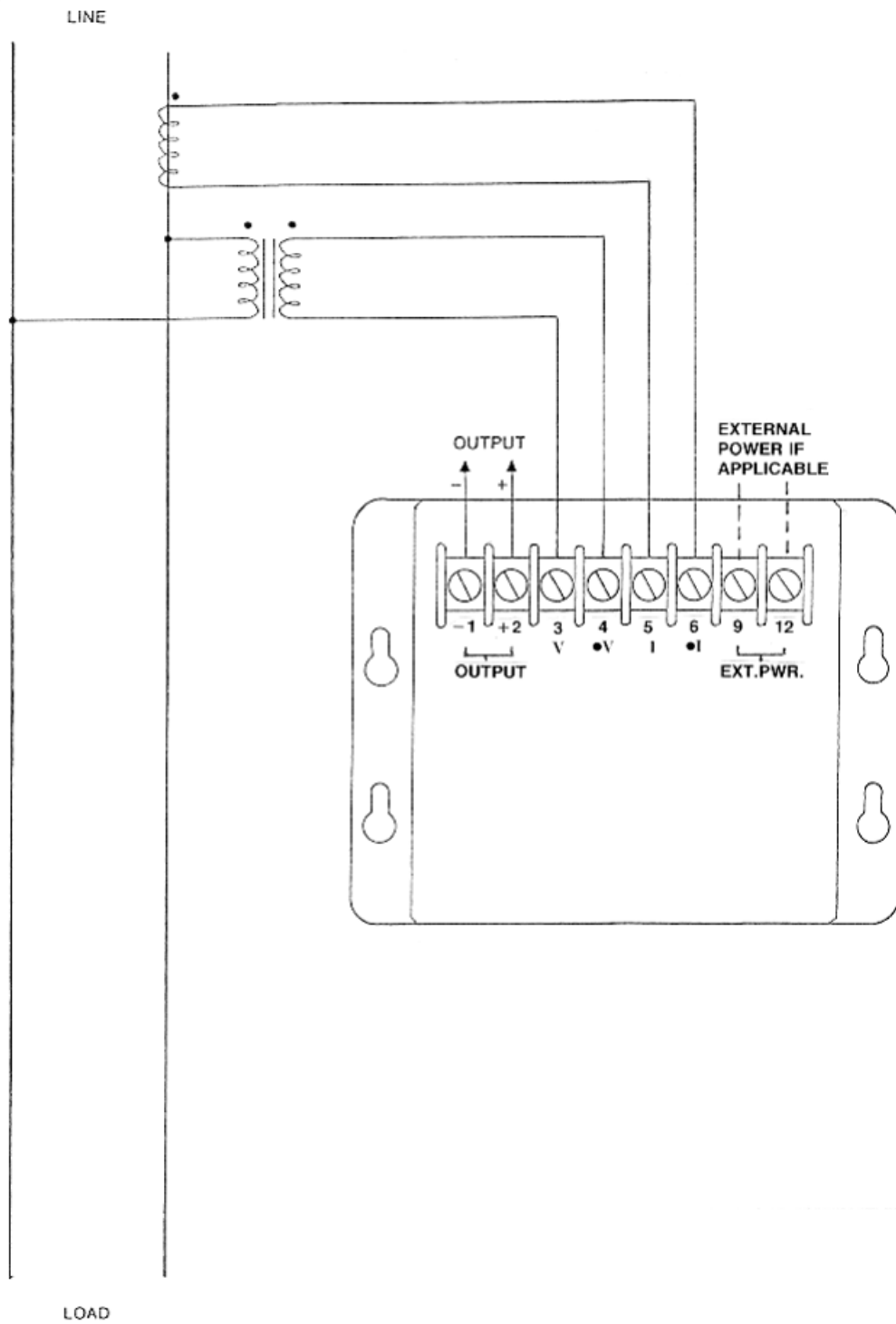

Figure 1. Connection Diagram, 1 Element Watt Transducer
Specifications subject to change

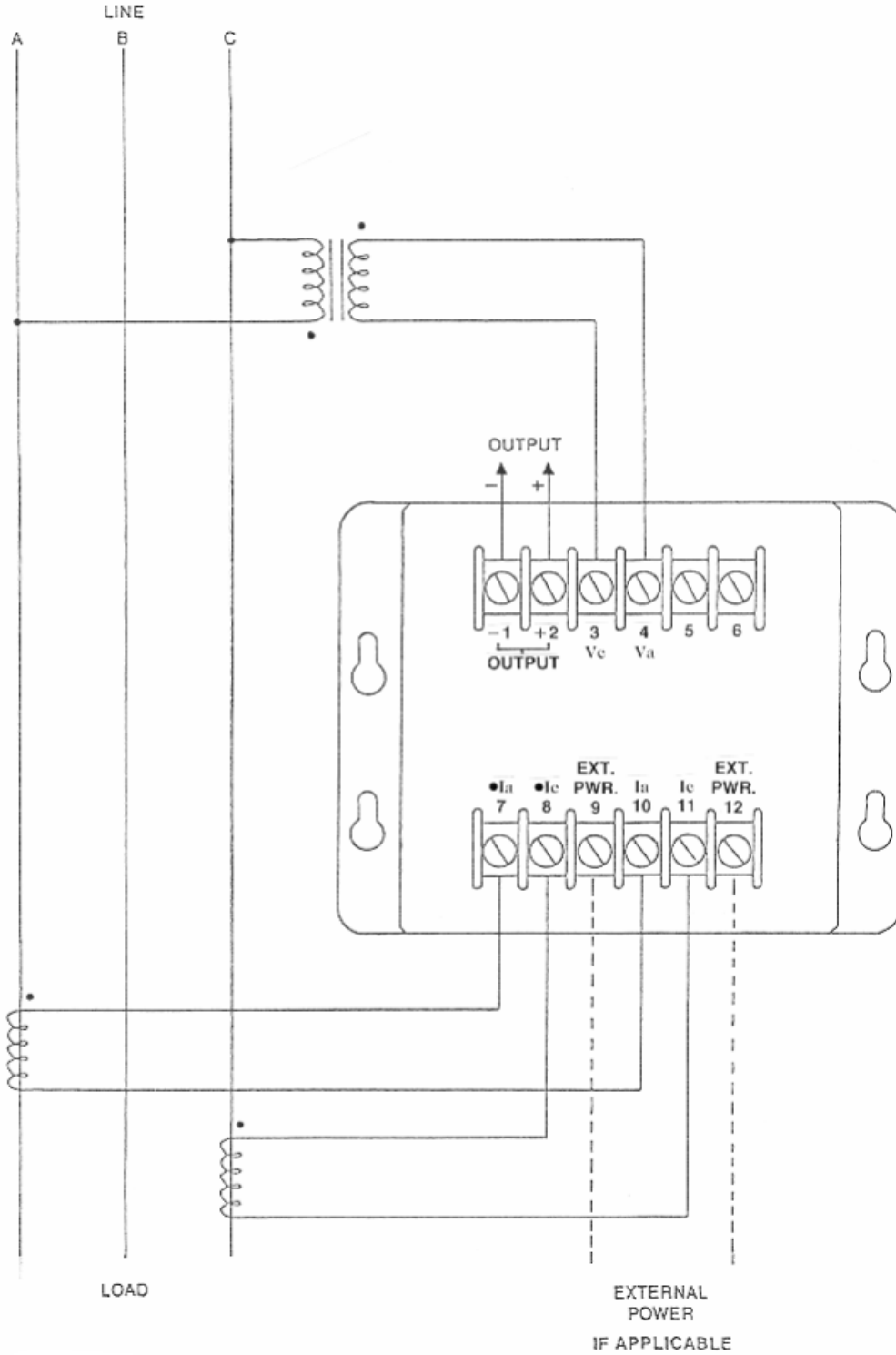

Figure 2. Connection Diagram, 1 1/2 Element Watt Transducer

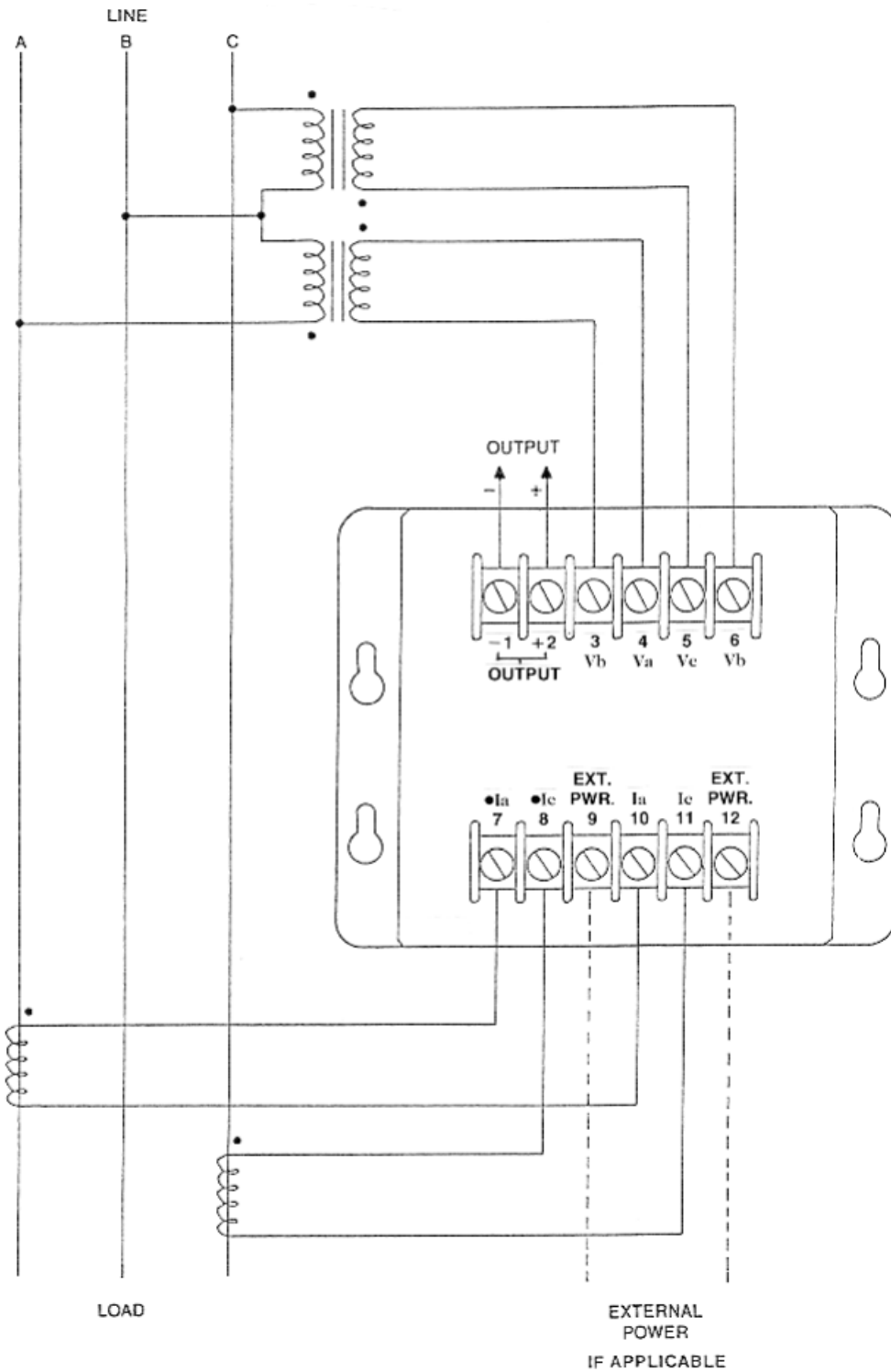

Figure 3. Connection Diagram, 2 Element Watt Transducer

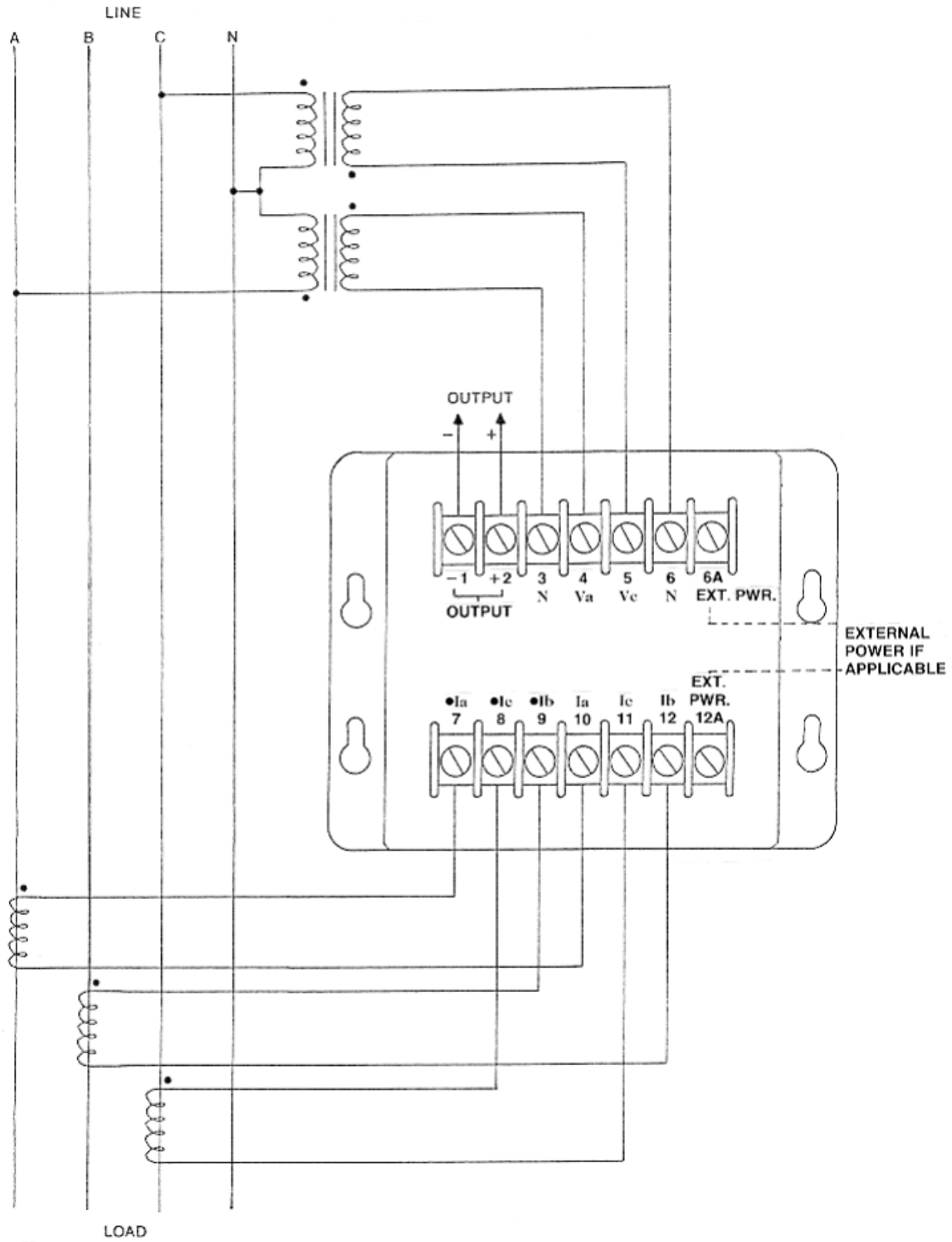

Figure 4. Connection Diagram, 2 1/2 Element Watt Transducer

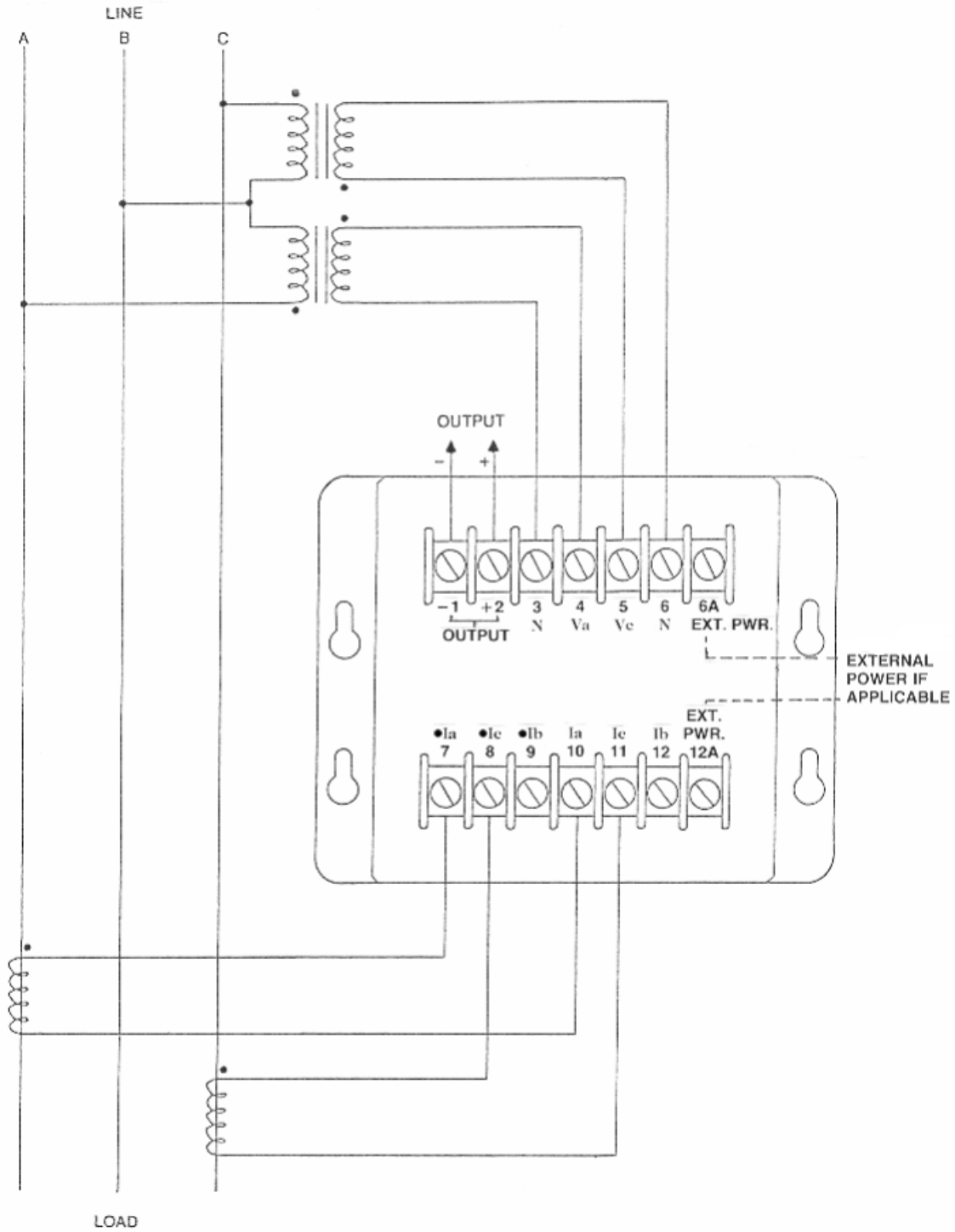

Figure 5. Connection Diagram, 2 1/2 Element Connected as 2 Element Watt Transducer

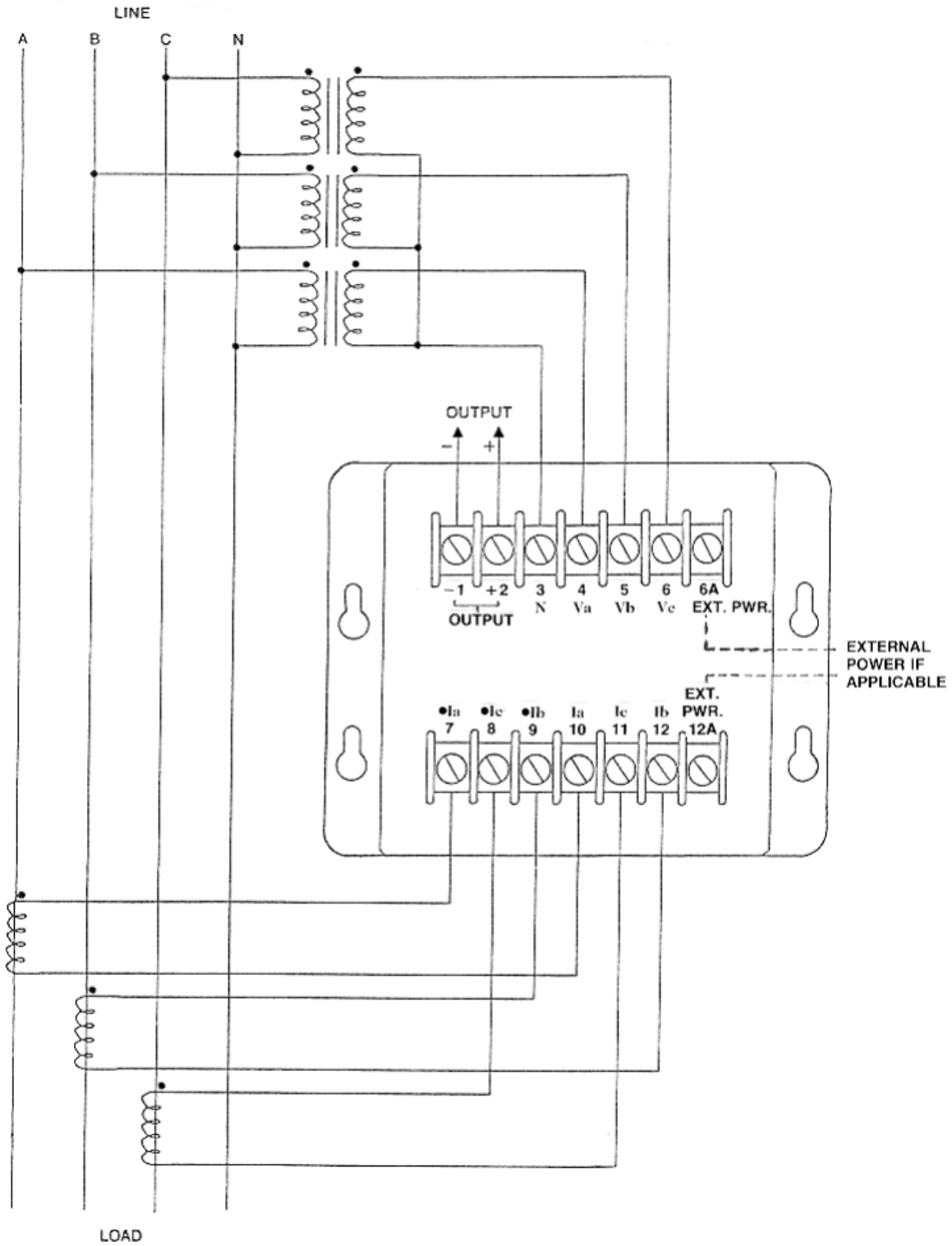

Figure 6. Connection Diagram, 3 Element Watt Transducer

Calibration

Introduction

This section provides information necessary for unit calibration. Each unit is calibrated and checked for proper performance at the factory before shipping. The following calibration procedure is for units with 120Vac, 5A input (500 watts per element), and 0 \pm 1mA full scale output.

NOTE

Increase or decrease the input current proportionally for more or less than the standard 500 watt per element to suit your particular transducer.

Null Balance Method

Equipment Required

- Calibrated MII power transducer with the same input, output and number of elements as the unit under test
- DC Volt Meter (3-1/2 digit, must be accurate to within 0.05%, 1V full scale)
- AC Voltmeter (0-150Vac)
- AC Ammeter (0-5Aac)
- 1000 watt electric heater or similar load
- Two 10K ohm precision resistors (accurate to within .01%)

Procedure (1-, 2-, and 3-element transducers)

Connect the equipment listed above, as shown in figures 7, 9, 11 and 12. The same current and voltage is applied to both the

control unit and the transducer under test, so the output of each should be identical. Any error is displayed on the meter as a reading. With 1V full scale 3-1/2 digit meter and 1mA full scale transducers, the reading increment is 1mV or 0.01% FS.

- 1 With the current switch SW1 open, adjust the input voltage for 120Vac on the voltmeter.
- 2 Check that there is no reading on the digital meter. If a reading is found, adjust the ZERO potentiometer on the transducer under test until the meter reads zero.
- 3 With the current switch SW1 closed, adjust the current to 4.167A on the ammeter.
- 4 Check that there is no reading on the digital meter. If a reading is found, adjust the CAL potentiometer on the transducer under test until the meter reads zero.
- 5 Linearity can be checked by adjusting the voltage and the current up and down within the specified range and checking the variance on the digital meter.

Procedure (1-1/2 and 2-1/2 element transducers)

Connect the equipment as shown in figures 8 and 10. Repeat steps 1-5, above, except the test current should be 2.08A for the 1-1/2 element transducer and 3.12A for the 2-1/2 element transducer.

Direct Method

Equipment Required

- Standard Wattmeter (must be accurate to within 0.1%, 600 watts full scale)
- DC Current Meter (3-1/2 digit, must be accurate to within 0.05%, 1mA full scale)
- AC Voltmeter (0-150Vac)
- AC Ammeter (0-5A)
- 1000 watt electric heater or similar load

Procedure (1-, 2-, and 3-element transducers)

Connect the equipment listed above, as shown in figures 13, 15, 17, and 18. The same current and voltage is applied to both the control unit and the transducer under test, so the output of the transducer should be proportional to the reading on the control unit.

- 1 With the current switch SW1 open, adjust the input voltage for 120Vac on the voltmeter.
- 2 Check that there is no reading on the digital meter. If a reading is found, adjust the ZERO potentiometer on the transducer under test until the meter reads zero.
- 3 With the current switch SW1 closed, adjust the current until the wattmeter reads 500.0 Watts.

4 Check the reading on the digital meter and adjust the CAL potentiometer on the transducer under test for 1.000mA

5 Linearity can be checked by adjusting the voltage and the current up and down within the specified range and comparing the readings on the two meters.

Procedure (1-1/2 and 2-1/2 element transducers)

Connect the equipment as shown in figures 14 and 16. Repeat steps 1-5, above, except the test current should be 2.08A for the 1-1/2 element transducer and 3.12A for the 2-1/2 element transducer.

Calibration should be checked every six months. Units may be returned to the factory for calibration.

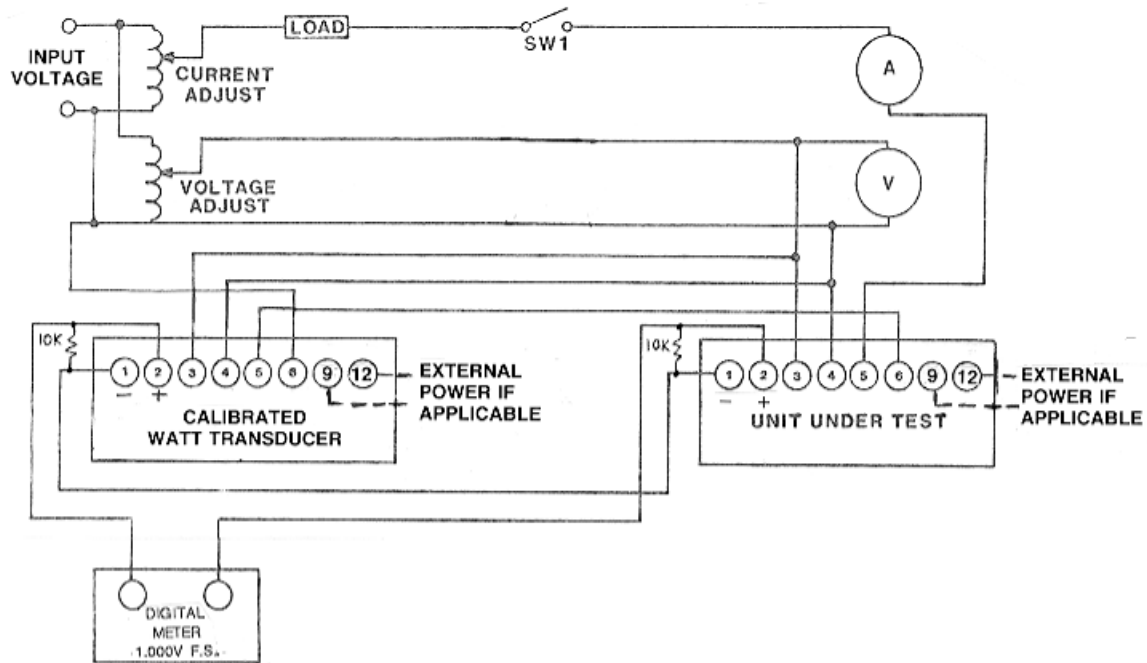

Figure 7. Calibration Procedure Null Method, 1 Element Watt Transducer

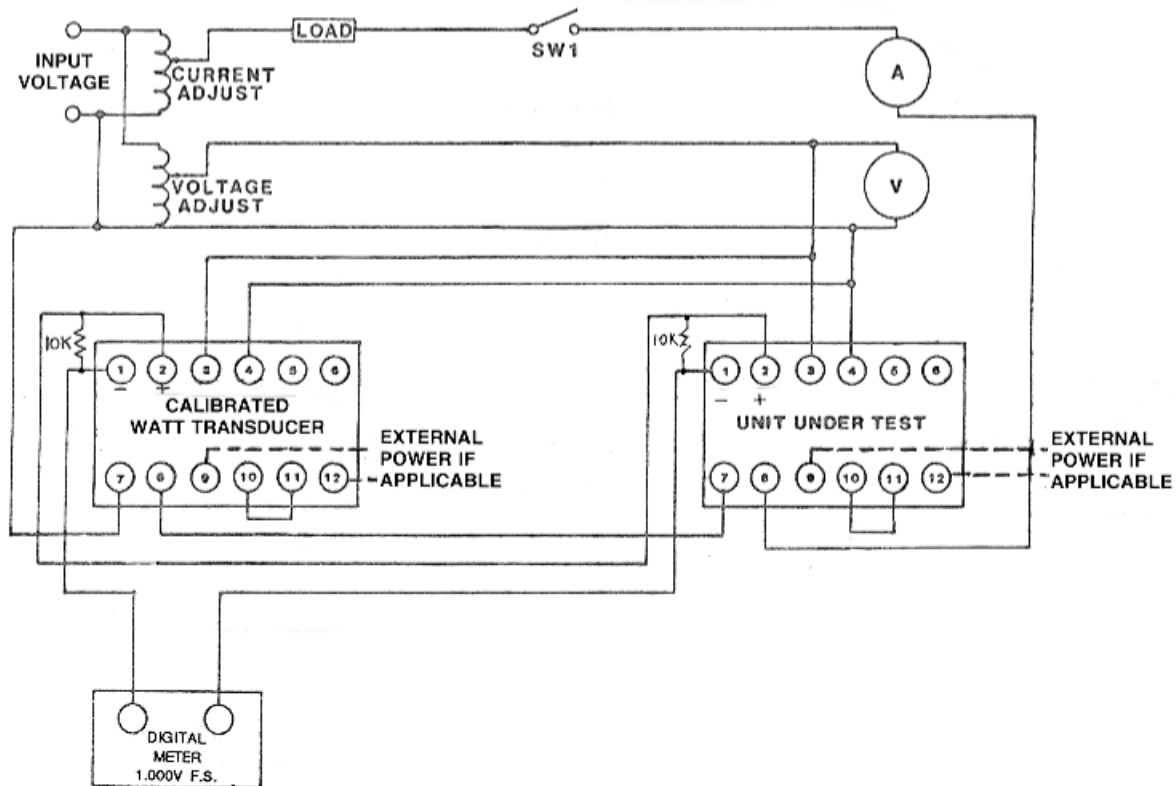

Figure 8. Calibration Procedure Null Method, 1 1/2 Element Watt Transducer

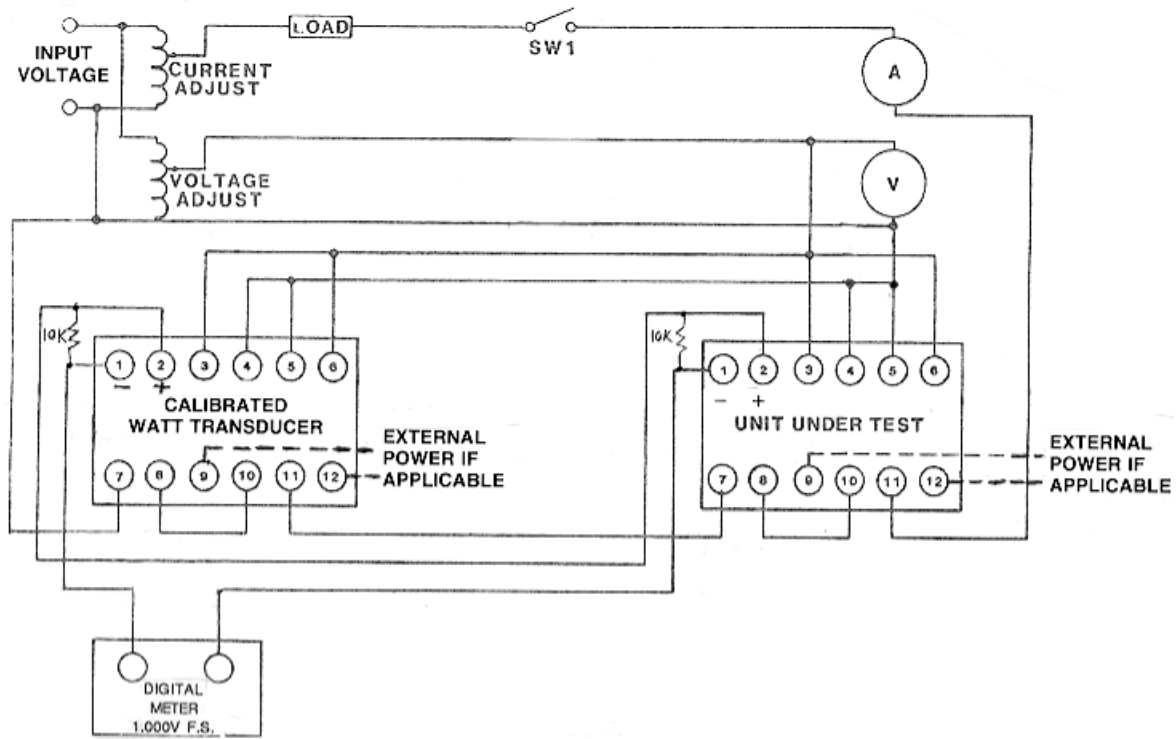

Figure 9. Calibration Procedure Null Method, 2 Element Watt Transducer

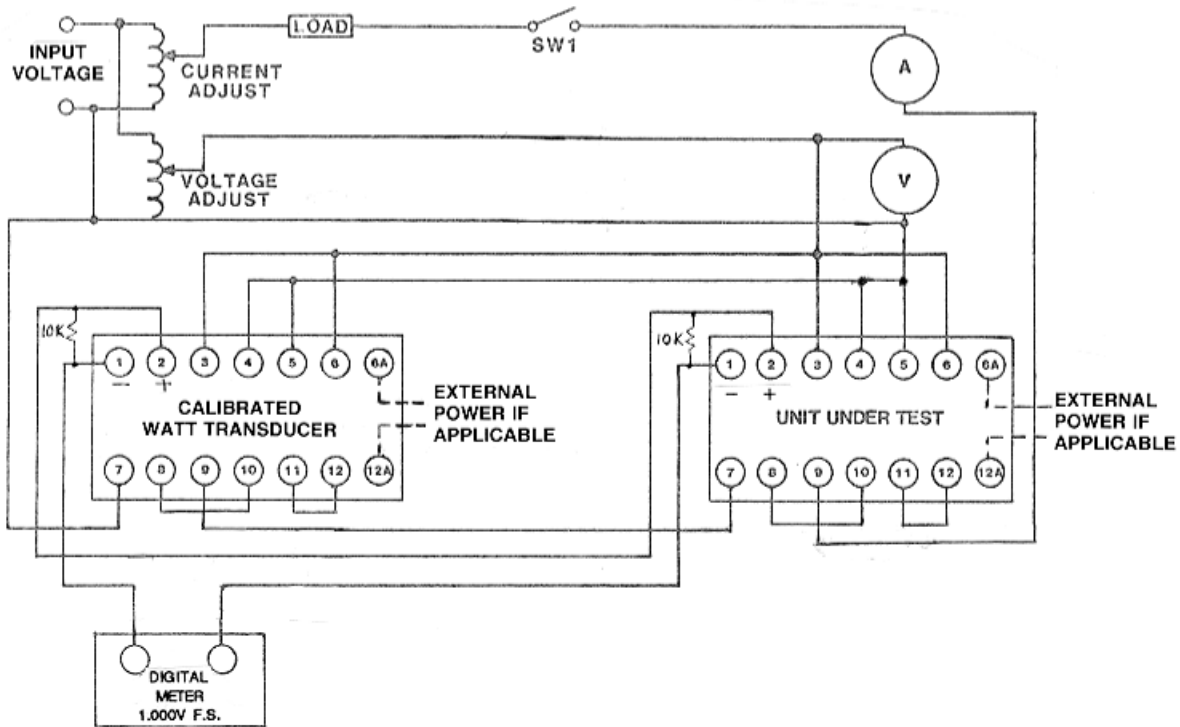

Figure 10. Calibration Procedure Null Method, 2 1/2 Element Watt Transducer

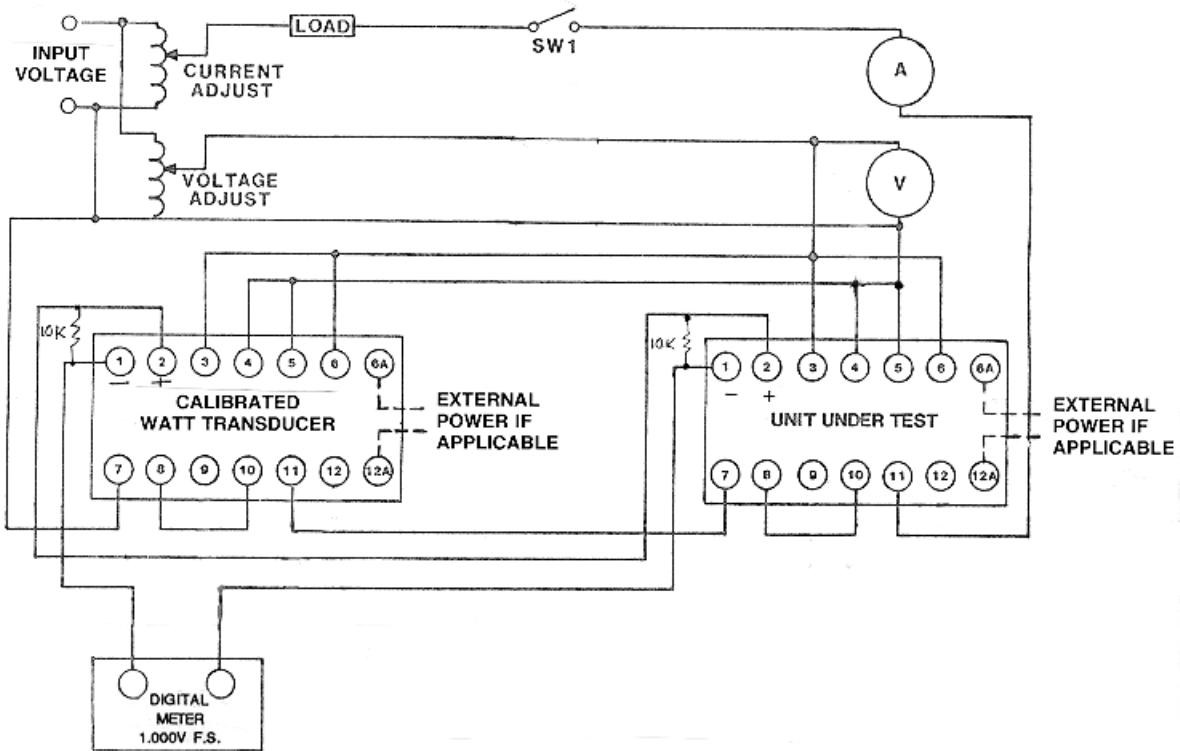

Figure 11. Calibration Procedure Null Method, 2 1/2 Element Connected as 2 Element Watt Transducer

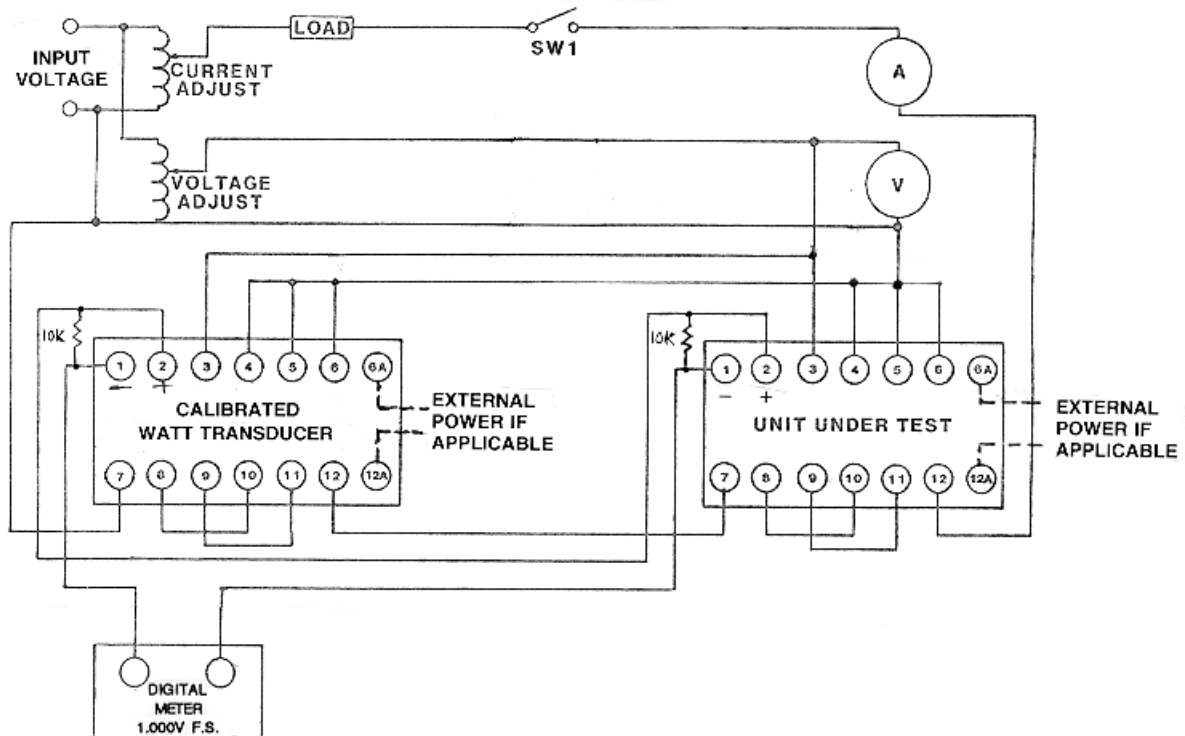

Figure 12. Calibration Procedure Null Method, 3 Element Watt Transducer

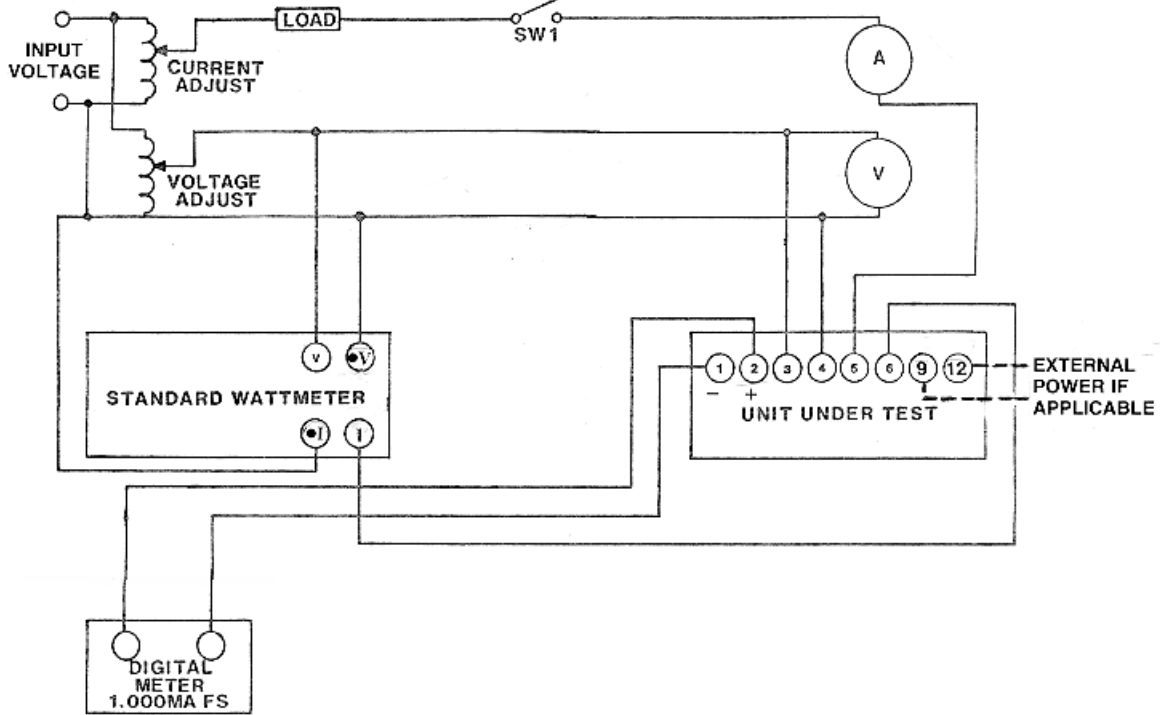

Figure 13. Calibration Procedure Direct Method, 1 Element Watt Transducer

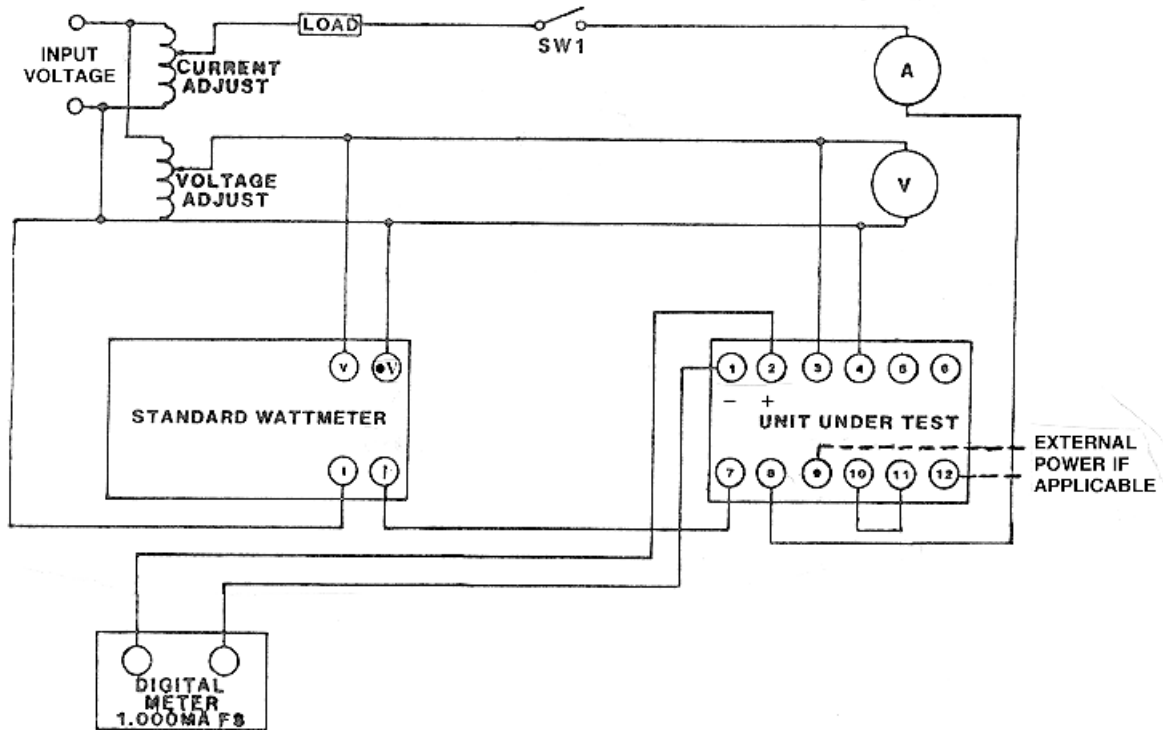

Figure 14. Calibration Procedure Direct Method, 1 1/2 Element Watt Transducer

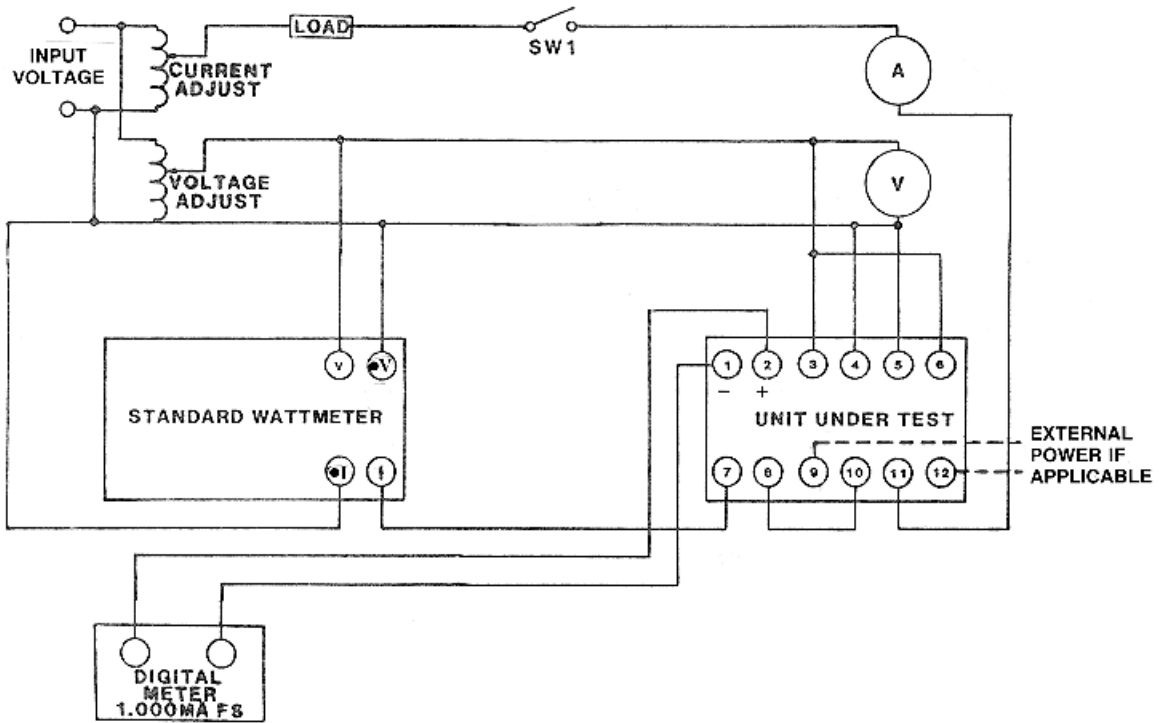

Figure 15. Calibration Procedure Direct Method, 2 Element Watt Transducer

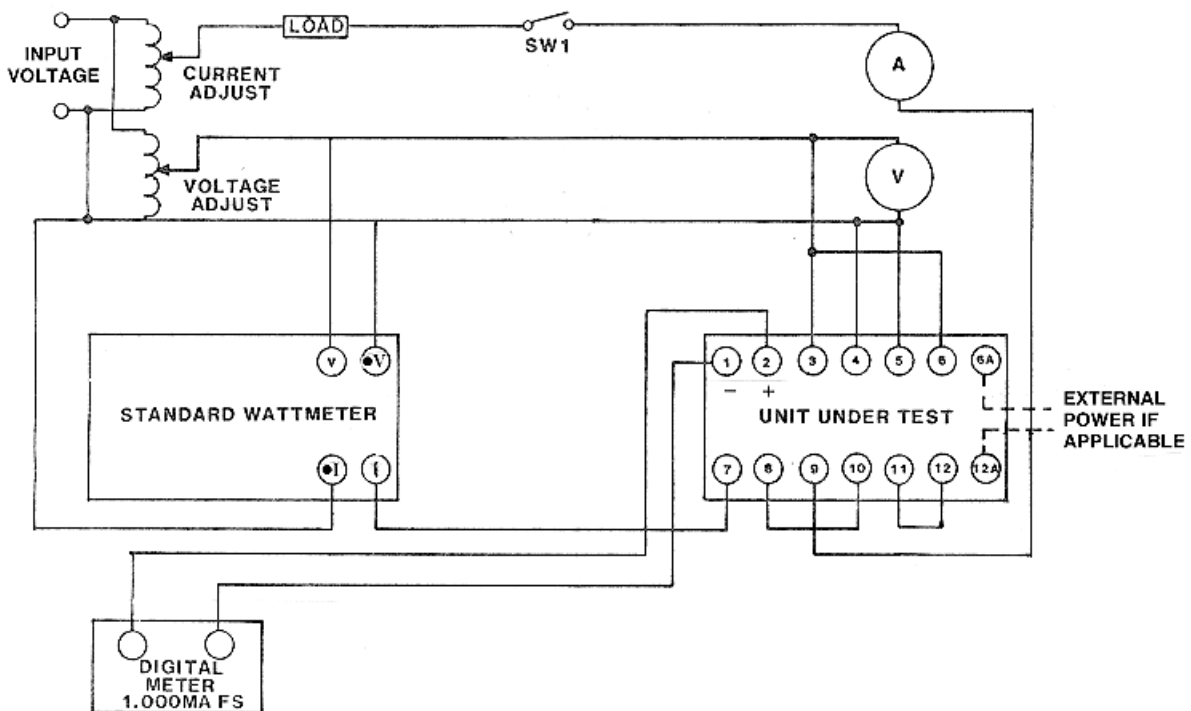

Figure 16. Calibration Procedure Direct Method, 2 1/2 Element Watt Transducer

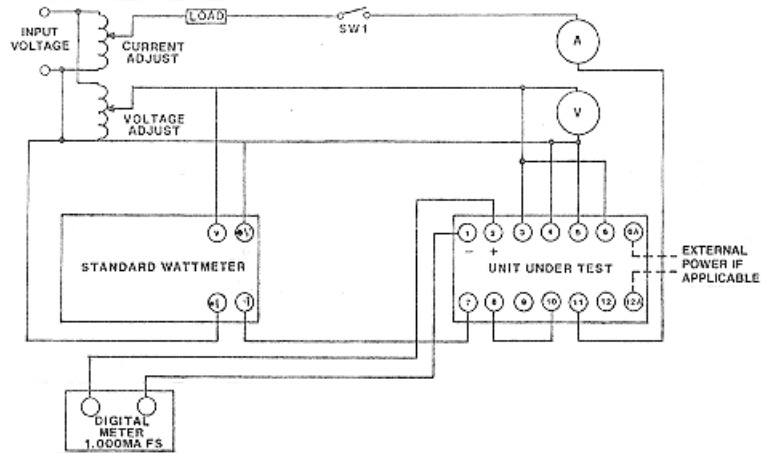

Figure 17. Calibration Procedure Direct Method, 2 1/2 Element Connected as 2 Element Watt Transducer

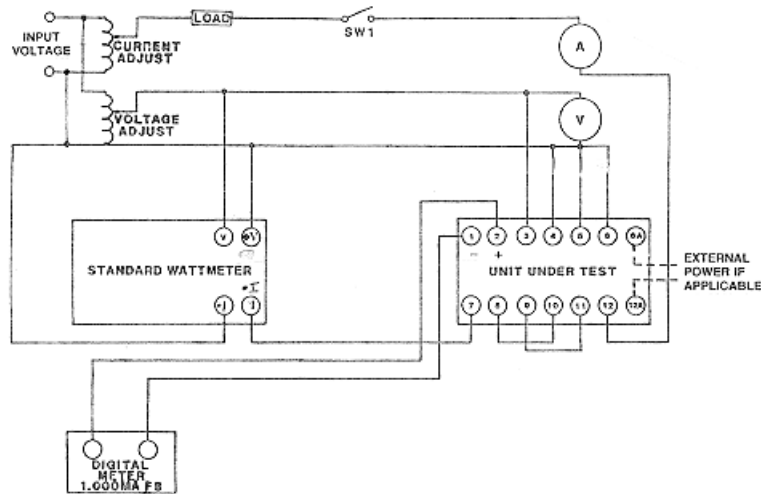

Figure 18. Calibration Procedure Direct Method, 3 Element Watt Transducer



UNITED STATES

DO NOT SCALE DRAWING

TOLERANCES UNLESS NOTED

3X = ± .001
 2X = ± .002
 1X = ± .005
 ANGLES = ± 30°
 UNLESS PER DIM
 STANDARD DIMENSIONS IN INCHES

CATEGORY: **SCHEMATIC**

TABLE: **PWT 1 & 1/2 ELEMENTS**

DRAWING NUMBER: **312-401-00**

REVISED BY: **ECO No 6691**

REVISION: **8**

DATE: **11/18/78**

APPROVAL: **JAW**

NOTICE OF PROPRIETARY INFORMATION: This drawing and the information contained herein are the proprietary property of Moore Industries - International, Inc. (MI) and should not be reproduced or disclosed to any third party without the written consent of an authorized officer of MI.

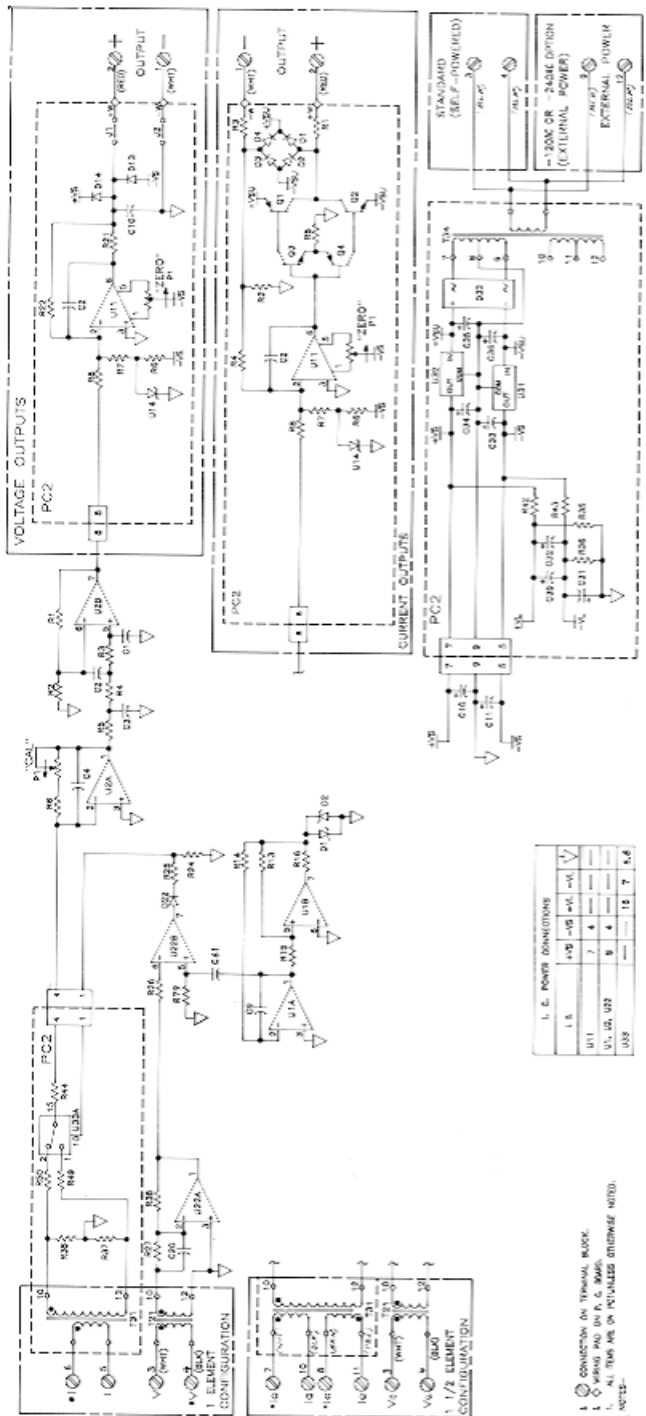

I. C. POWER CONNECTIONS

U1	1	15	7	8,4
U2	1	15	7	8,4
U3	1	15	7	8,4
U4	1	15	7	8,4
U5	1	15	7	8,4
U6	1	15	7	8,4
U7	1	15	7	8,4
U8	1	15	7	8,4
U9	1	15	7	8,4
U10	1	15	7	8,4
U11	1	15	7	8,4
U12	1	15	7	8,4
U13	1	15	7	8,4
U14	1	15	7	8,4
U15	1	15	7	8,4
U16	1	15	7	8,4
U17	1	15	7	8,4
U18	1	15	7	8,4
U19	1	15	7	8,4
U20	1	15	7	8,4
U21	1	15	7	8,4
U22	1	15	7	8,4
U23	1	15	7	8,4
U24	1	15	7	8,4
U25	1	15	7	8,4
U26	1	15	7	8,4
U27	1	15	7	8,4
U28	1	15	7	8,4
U29	1	15	7	8,4
U30	1	15	7	8,4
U31	1	15	7	8,4
U32	1	15	7	8,4
U33	1	15	7	8,4
U34	1	15	7	8,4
U35	1	15	7	8,4
U36	1	15	7	8,4
U37	1	15	7	8,4
U38	1	15	7	8,4
U39	1	15	7	8,4
U40	1	15	7	8,4
U41	1	15	7	8,4
U42	1	15	7	8,4
U43	1	15	7	8,4
U44	1	15	7	8,4
U45	1	15	7	8,4
U46	1	15	7	8,4
U47	1	15	7	8,4
U48	1	15	7	8,4
U49	1	15	7	8,4
U50	1	15	7	8,4
U51	1	15	7	8,4
U52	1	15	7	8,4
U53	1	15	7	8,4
U54	1	15	7	8,4
U55	1	15	7	8,4
U56	1	15	7	8,4
U57	1	15	7	8,4
U58	1	15	7	8,4
U59	1	15	7	8,4
U60	1	15	7	8,4
U61	1	15	7	8,4
U62	1	15	7	8,4
U63	1	15	7	8,4
U64	1	15	7	8,4
U65	1	15	7	8,4
U66	1	15	7	8,4
U67	1	15	7	8,4
U68	1	15	7	8,4
U69	1	15	7	8,4
U70	1	15	7	8,4
U71	1	15	7	8,4
U72	1	15	7	8,4
U73	1	15	7	8,4
U74	1	15	7	8,4
U75	1	15	7	8,4
U76	1	15	7	8,4
U77	1	15	7	8,4
U78	1	15	7	8,4
U79	1	15	7	8,4
U80	1	15	7	8,4
U81	1	15	7	8,4
U82	1	15	7	8,4
U83	1	15	7	8,4
U84	1	15	7	8,4
U85	1	15	7	8,4
U86	1	15	7	8,4
U87	1	15	7	8,4
U88	1	15	7	8,4
U89	1	15	7	8,4
U90	1	15	7	8,4
U91	1	15	7	8,4
U92	1	15	7	8,4
U93	1	15	7	8,4
U94	1	15	7	8,4
U95	1	15	7	8,4
U96	1	15	7	8,4
U97	1	15	7	8,4
U98	1	15	7	8,4
U99	1	15	7	8,4
U100	1	15	7	8,4

1. CONNECTION ON TERMINAL BLOCK.
 2. CONNECTION ON P.C. BOARD.
 3. ALL TRAPS ARE TO BE USED UNLESS OTHERWISE NOTED.
 NOTE-

 MOORE INDUSTRIES	DO NOT SCALE DRAWING		CATEGORY P.C. ASSEMBLY	DRAWING NUMBER 312-501-00	REVISION A
	TOLERANCES UNLESS NOTED .X + .1 .XX + .03 .XXX + .010 ANGLES: ± 30° HOLES: PER SAE STANDARD DIMENSIONS IN INCHES	DRAWN <i>[Signature]</i>	CHECKED <i>[Signature]</i>	TITLE PWT 1 AND 1/2 ELEMENT VOLTAGE BOARD (P.C. 1)	REVISOR INITIAL RELEASE
UNITED STATES	ENGINEER <i>[Signature]</i>	SCALE 60%	APPROVAL <i>[Signature]</i>	NOTICE RE PROPRIETARY INFORMATION: This drawing and the information contained herein are the property of Moore Industries, Inc. (MII) and should not be reproduced or disclosed to any third party without the written consent of an authorized officer of MII.	

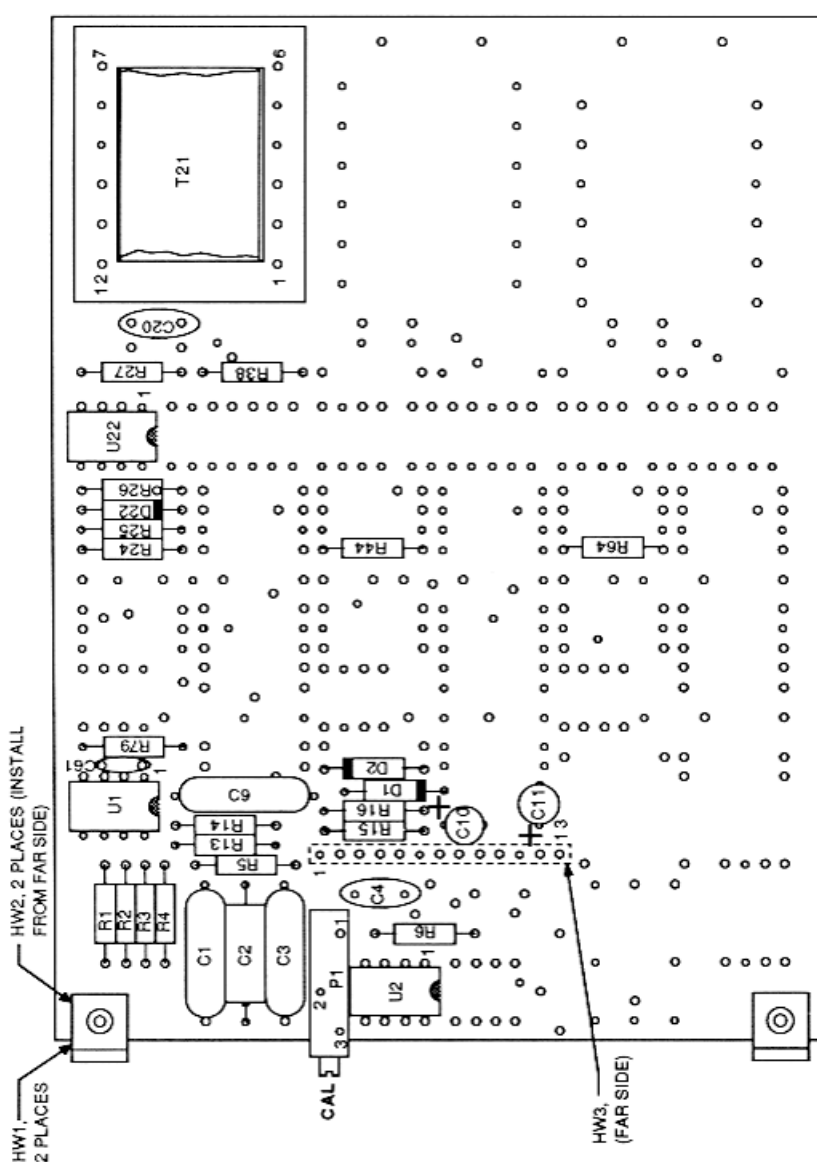

- INSTALL P1 POT FLAT ON BOARD.
 - ALL LEADS MUST BE SOLDERED TO PADS.
 - ALL JUMPERS ARE 22 AWG BUS. TEFLON SLEEVED AS REQUIRED.
- NOTES-



MOORE INDUSTRIES

UNITED STATES

DO NOT SCALE DRAWING

TOLERANCES UNLESS NOTED
 X = ±.1
 XX = ±.00
 ANGLES = ±.00
 HOLES PER SAE STANDARD
 DIMENSIONS IN INCHES
 SCALE FULL

DRAWN C. MATHEWS 01/88
 CHECKED *W. J. H.*
 ENGINEER *W. J. H.*
 1/85

CATEGORY

P. C. ASSEMBLY
PWT
1 & 1/2 ELEMENT
CURRENT BOARD
(PC2)

DRAWING NUMBER

312-504-00

REVISED BY

ECO 6662

DATE

1/98

BY

CA

APPROVAL

W

REVISION

B

NOTICE RE PROPRIETARY INFORMATION: This drawing and the information contained herein are the proprietary property of Moore Industries - International, Inc. (MII) and should not be reproduced or disclosed to any third party without the written consent of an authorized officer of MII.

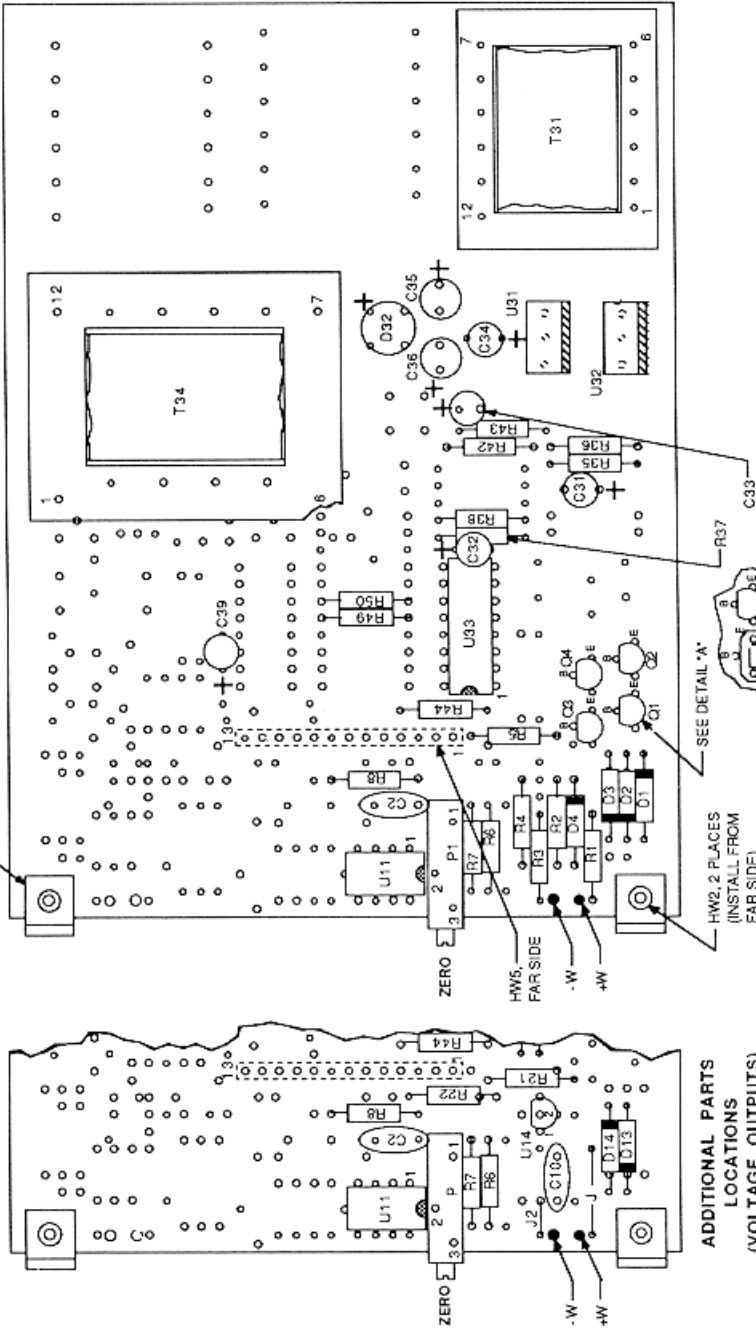

ADDITIONAL PARTS LOCATIONS (VOLTAGE OUTPUTS)

- INSTALL P1 POT FLAT ON BOARD.
- ALL LEADS MUST BE SOLDERED TO PADS.
- ALL JUMPERS ARE 22 AWG BUS, TEFLOX SLEEVED AS REQUIRED.

NOTES



DO NOT SCALE DRAWING

TOLERANCES UNLESS NOTED
 X .1
 XX .05
 XXX .01
 ANGLES .50
 DIMENSIONS PER ASME STANDARD
 DIMENSIONS IN INCHES

DESIGN: P. Kelly
 CHECKED: [Signature]
 ENGINEER: [Signature]
 SCALE:

CATEGORY: SCHEMATIC
 TITLE: PWT
 2 & 1/2 ELEMENTS

DRAWING NUMBER: 312-402-00
 REVISION: B

REVISED BY: [Signature]
 DATE: 10/28/87
 APPROVAL: [Signature]

NOTICE: ALL PROPRIETARY INFORMATION: This drawing and the information contained herein are the proprietary property of Moore Industries, International, Inc. (MI) and should not be reproduced or disclosed to any third party without the written consent of an authorized officer of MI.

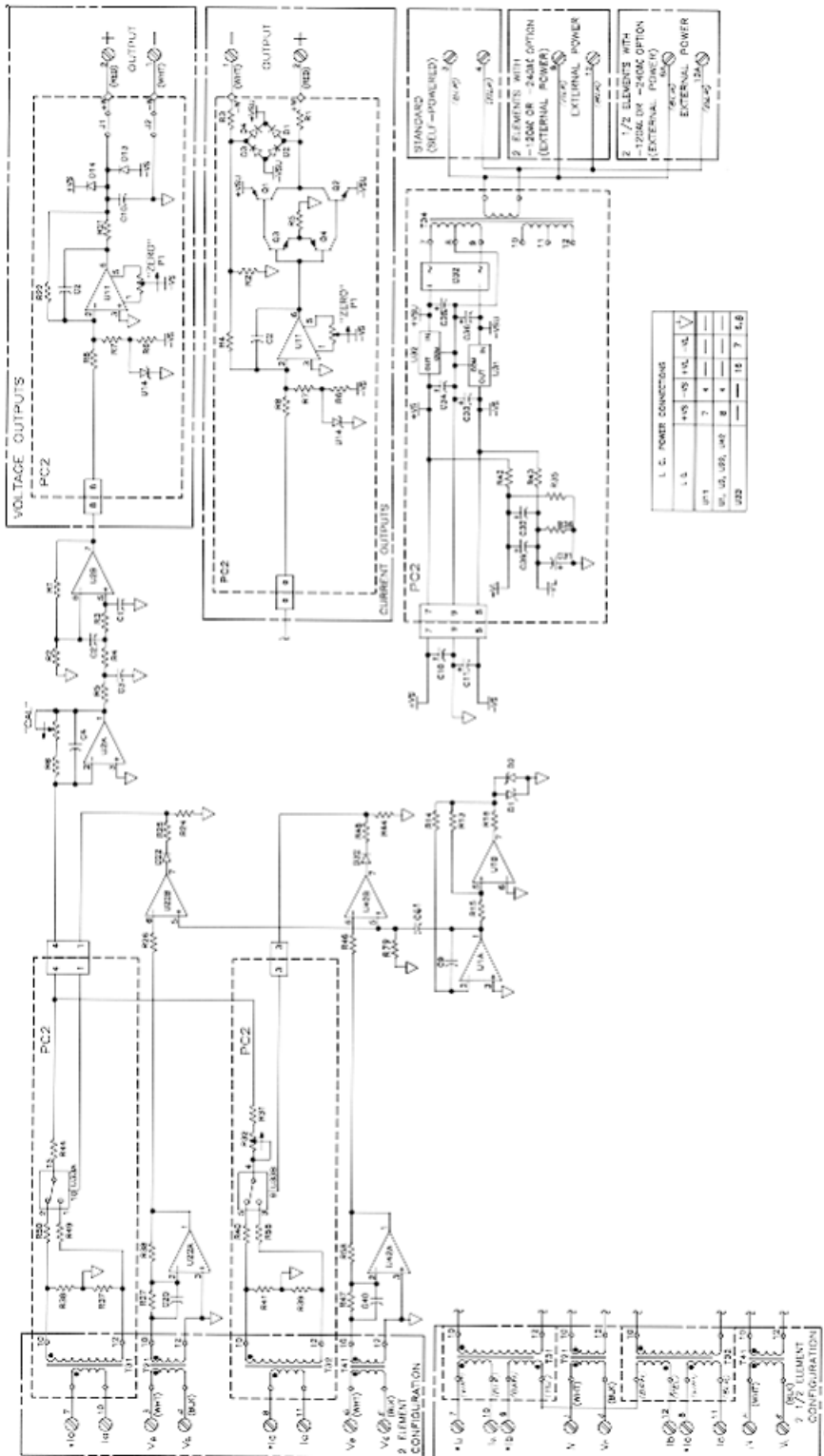

NOTES:
 1. CONNECTION ON TERMINAL BLOCK.
 2. WIND PAD ON P. C. BOARD.
 3. ALL DIM. ARE IN INCHES UNLESS NOTED.

 MOORE INDUSTRIES UNITED STATES	DO NOT SCALE DRAWING DRAWN: <i>[Signature]</i> CHECKED: <i>[Signature]</i> ENGINEER: <i>[Signature]</i> SCALE: 60%		CATEGORY: <i>P.C. ASSEMBLY</i> TITLE: <i>PWT 2 AND 2 1/2 ELEMENT VOLTAGE BOARD (P.C. 1)</i>	DRAWING NUMBER: <i>312-502-00</i> REVISION: <i>A</i>
	TOLERANCES UNLESS NOTED: .X = ±.1 .XX = ±.03 .XXX = ±.010 ANGLES: = 90 HOLES: PER SAE STANDARD	DIMENSIONS IN INCHES	REVISED BY: <i>INITIAL RELEASE</i> DATE: <i>1/14/72</i> BY: <i>[Signature]</i> APPROVAL: <i>JAD</i>	NOTICE RE PROPRIETARY INFORMATION: This drawing and the information contained herein are the proprietary property of Moore Industries - International, Inc. (MII) and should not be reproduced or disclosed to any third party without the written consent of an authorized officer of MII.

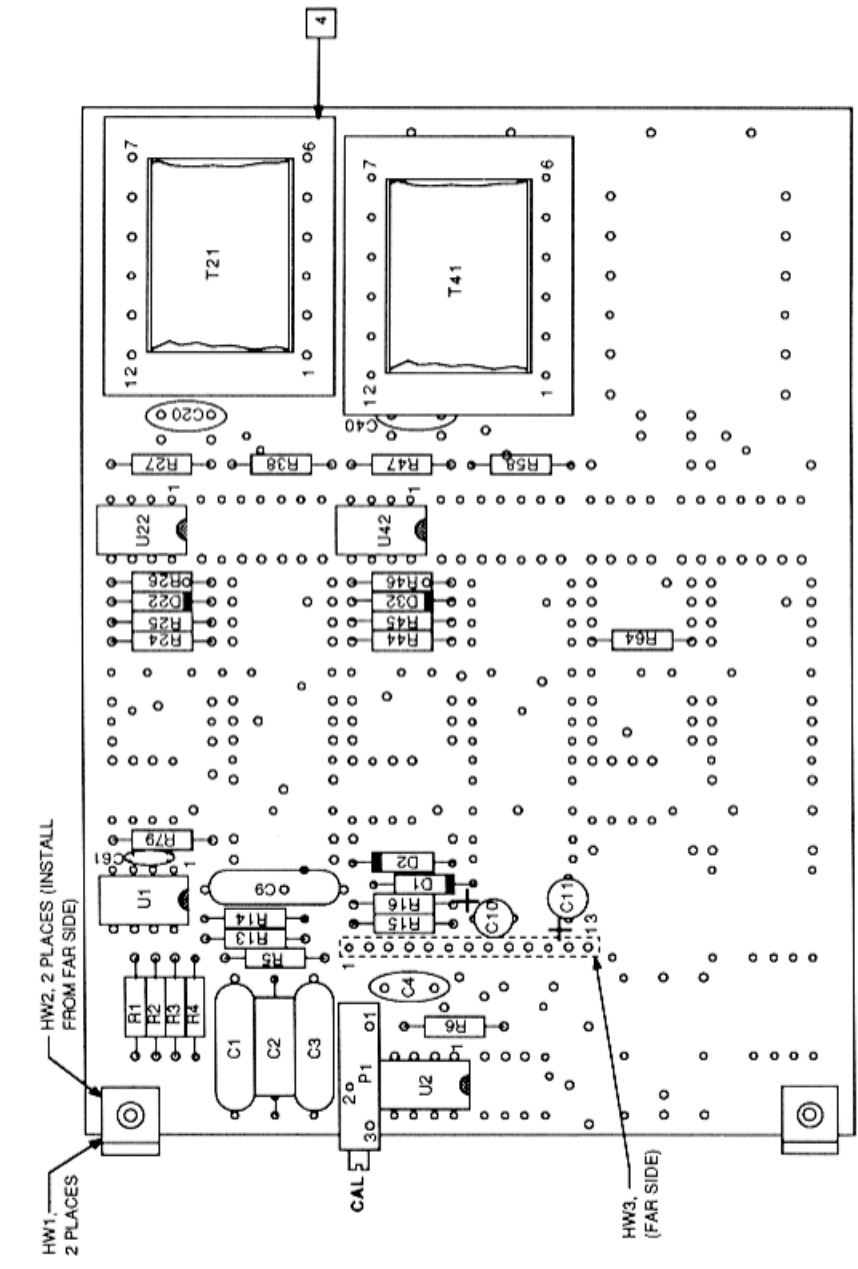

- 4] SIDE PINS OF T21 FACING T41 MUST BE CUT OFF.
 3. INSTALL P1 POT FLAT ON BOARD.
 2. ALL LEADS MUST BE SOLDERED TO PADS.
 1. ALL JUMPERS ARE 22 AWG BUS, TEFLON SLEEVED AS REQUIRED.
- NOTES:

DO NOT SCALE DRAWING

DRWNG: C. MATHEWS D1/88

CHECKED: *[Signature]*

ENGINEER: *[Signature]*

SCALE: FULL

TOLERANCES UNLESS NOTED:
 X = ± .1
 .XX = ± .03
 .XXX = ± .010
 ANGLES: ± 30'
 HOLES: PER SAE STANDARD

DIMENSIONS IN INCHES

CATEGORY: P. C. ASSEMBLY

TITLE: PWT
 2 & 2 1/2 ELEMENT
 CURRENT BOARD
 (PC2)

DRAWING NUMBER: 312-505-00

REVISION: B

REVISOR: *[Signature]*

DATE: 11/1/88

BY: *[Signature]*

APPROVAL: *[Signature]*

NOTICE RE PROPRIETARY INFORMATION: This drawing and the information contained herein are the proprietary property of Moore Industries International, Inc. (MII) and should not be reproduced or disclosed to any third party without the written consent of an authorized officer of MII.

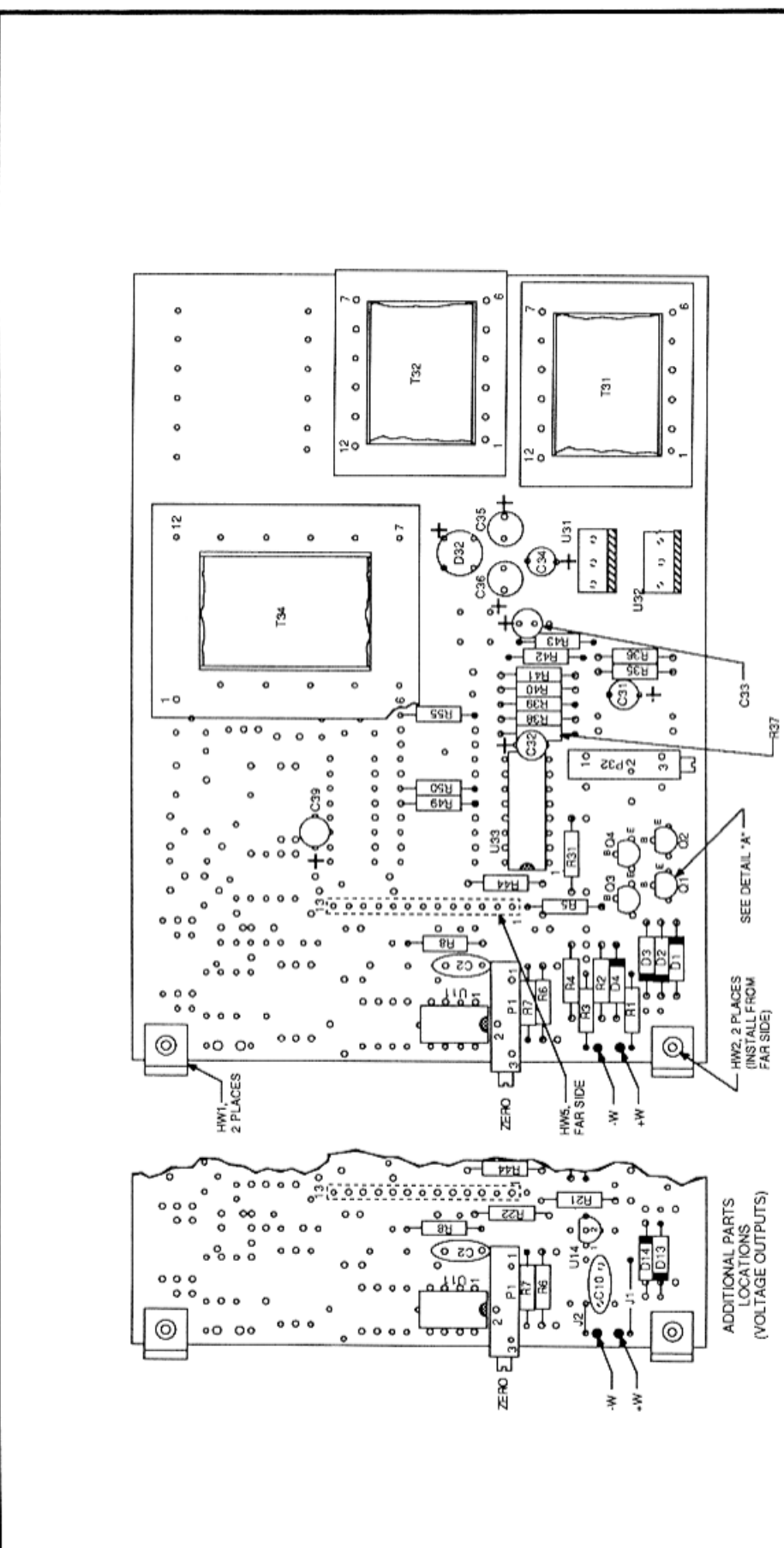

- ADDITIONAL PARTS LOCATIONS (VOLTAGE OUTPUTS)**
- 4 CUT OFF PINS OF T32 FACING T31.
 - 3. INSTALL P1 POT FLAT ON BOARD.
 - 2. ALL LEADS MUST BE SOLDERED TO PADS.
 - 1. ALL JUMPERS ARE 22 AWG BUS, TEFLON SLEEVED AS REQUIRED.
- NOTES: UNLESS OTHERWISE SPECIFIED.

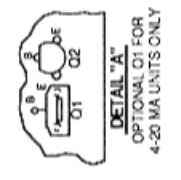

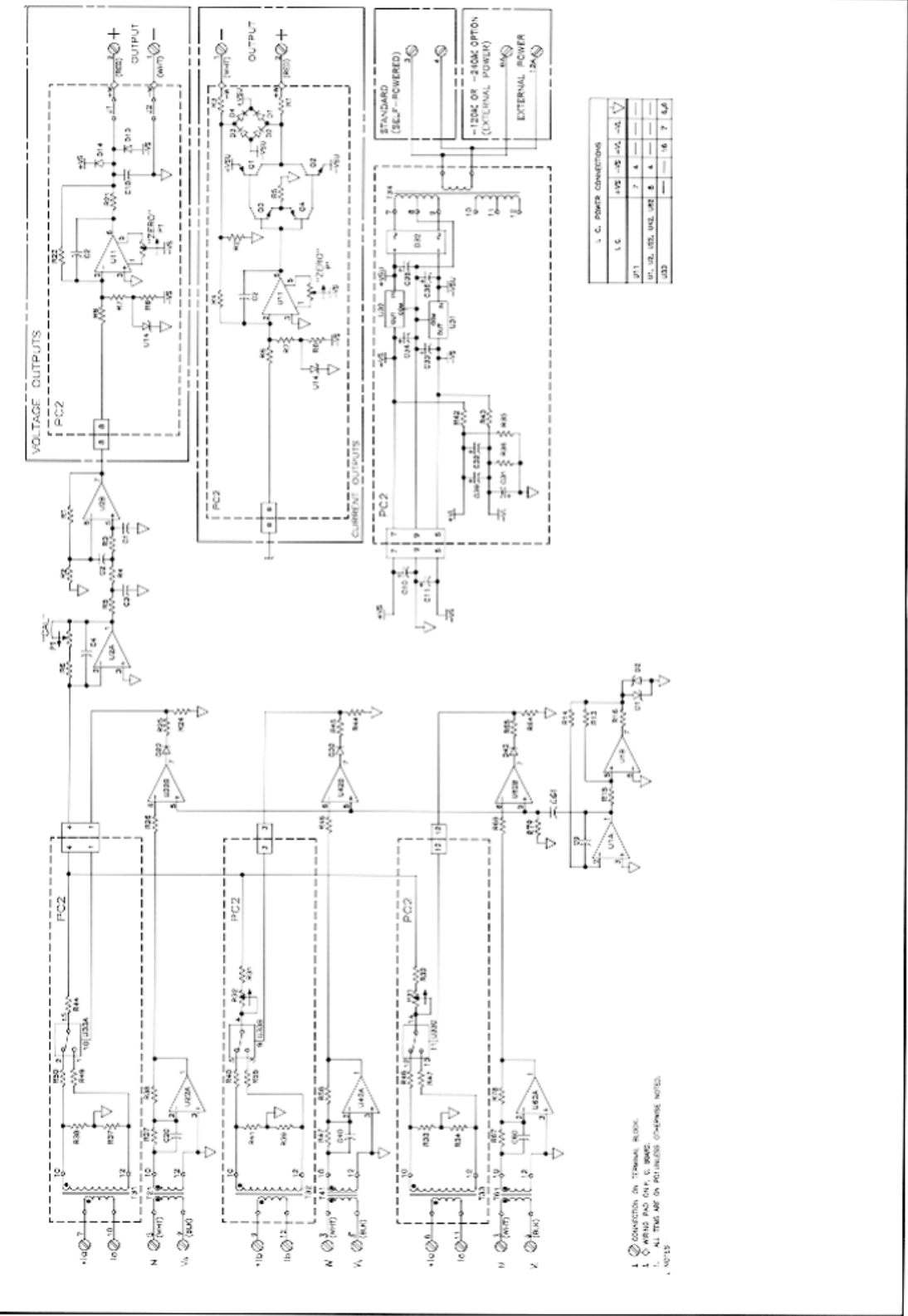



MOORE INDUSTRIES

UNITED STATES

DO NOT SCALE DRAWING

TOLERANCES UNLESS NOTED
 X = ±.1
 XX = ±.03
 .XXX = ±.010
 ANGLES: ±.30°
 HOLES: PER SAE STANDARD
 DIMENSIONS IN INCHES

CATEGORY: P.C. ASSEMBLY
 TITLE: PWT 3 ELEMENT BOARD (P.C.1)
 VOLTAGE BOARD

DRAWING NUMBER: 312-503-00
 REVISION: A
 REVISED BY: INITIAL RELEASE
 DATE: 11/1/84
 BY: CJD
 APPROVAL: JMD

NOTICE RE PROPRIETARY INFORMATION: This drawing and the information contained herein are the proprietary property of Moore Industries - International, Inc. (MI) and should not be reproduced or disclosed to any third party without the written consent of an authorized officer of MI.

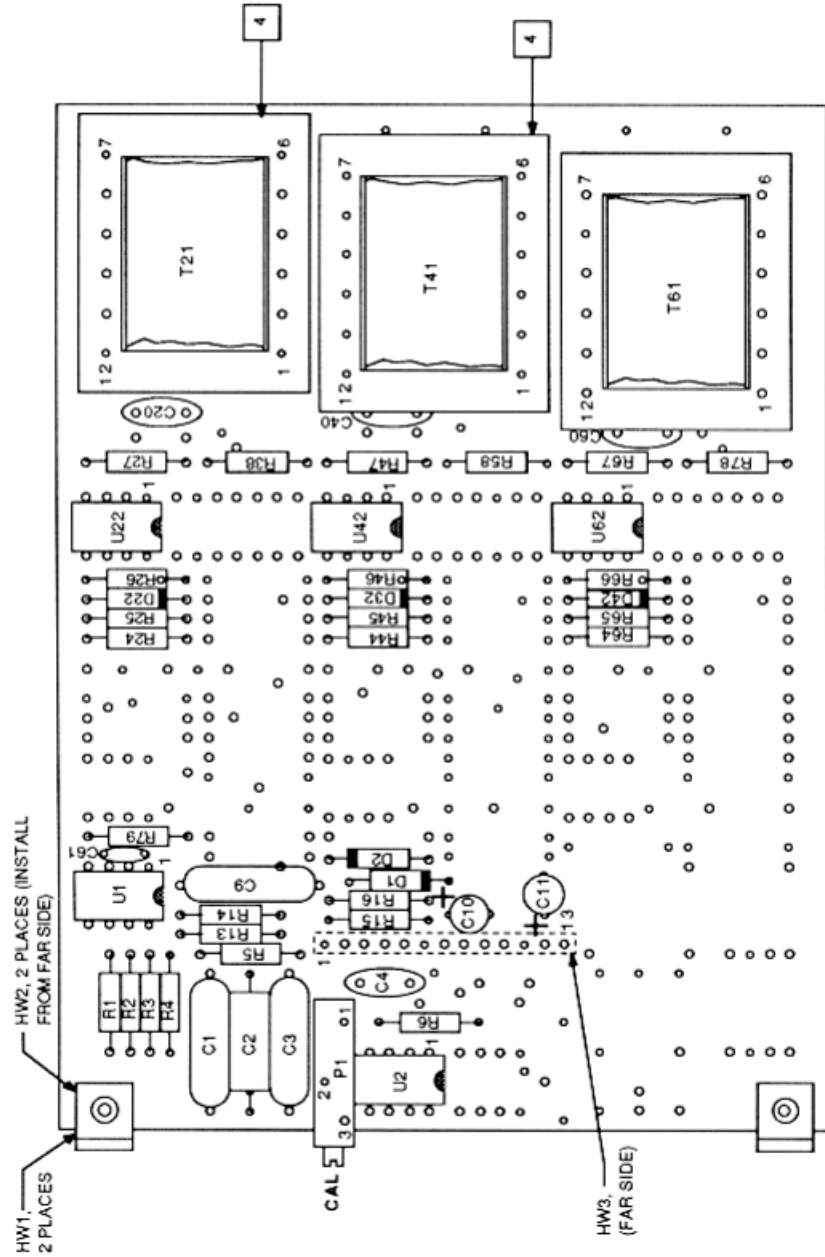

- 4. SIDE PINS OF T21 FACING T41 MUST BE CUT OFF, AND SIDE PINS OF T41 FACING T61 MUST BE CUT OFF.
- 3. INSTALL P1 POT FLAT ON BOARD.
- 2. ALL LEADS MUST BE SOLDERED TO PADS.
- 1. ALL JUMPERS ARE 22 AWG BUS, TEFLON SLEEVED AS REQUIRED.

NOTES:



UNITED STATES

DO NOT SCALE DRAWING

TOLERANCES UNLESS NOTED	DRAWN	CHECKED	DATE
.X = ±.1	<i>[Signature]</i>	<i>[Signature]</i>	11/14/82
.XX = ±.01			
.XXX = ±.010			
ANGLES: PER SAE STANDARD			
Holes: PER SAE STANDARD			
SCALE	60%		

CATEGORY

P.C. ASSEMBLY

TITLE

PWT
3 ELEMENT
VOLTAGE BOARD
(P.C.1)

DRAWING NUMBER

312-503-00

REVISION

APPROVAL

REVISED BY: INITIAL RELEASE
 DATE: 11/18/82
 BY: *[Signature]*

NOTICE RE PROPRIETARY INFORMATION: This drawing and the information contained herein are the proprietary property of Moore Industries - International, Inc. (MII) and should not be reproduced or disclosed to any third party without the written consent of an authorized officer of MII.

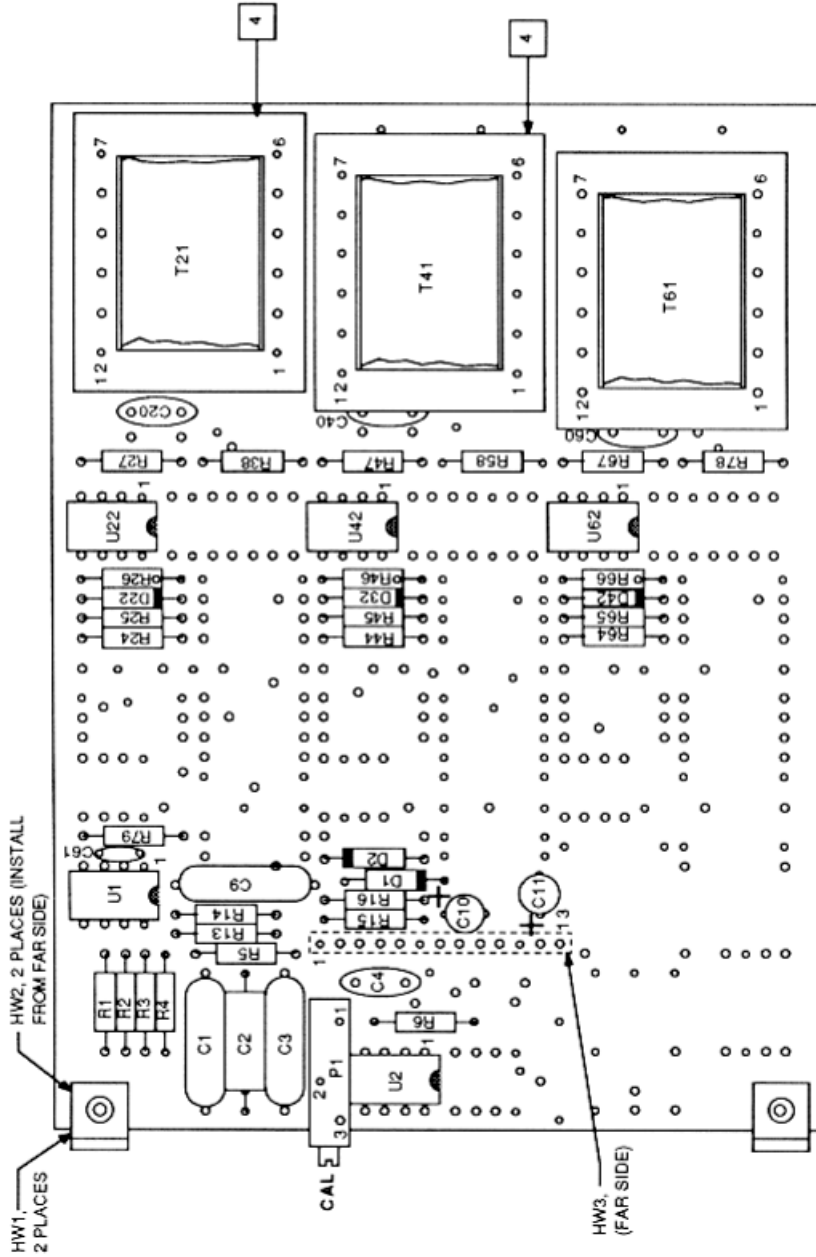

- 1. SIDE PINS OF T21 FACING T41 MUST BE CUT OFF, AND SIDE PINS OF T41 FACING T61 MUST BE CUT OFF.
- 2. INSTALL P1 POT FLAT ON BOARD.
- 3. ALL LEADS MUST BE SOLDERED TO PADS.
- 4. ALL JUMPERS ARE 22 AWG BUS, TEFLON SLEEVED AS REQUIRED.

NOTES-

	DO NOT SCALE DRAWING		CATEGORY P. C. ASSEMBLY	DRAWING NUMBER 312-506-00	REVISION B
	TOLERANCES UNLESS NOTED .X = .1 .XX = .03 .XXX = .010 ANGLES: ±.30° HOLES: PER SAE STANDARD	DRAWN C. MATHEWS	D1/88	TITLE PWT 3 ELEMENT CURRENT BOARD (PC2)	REVISED BY ECO 6662
CHECKED W. J. [Signature]	ENGINEER K. [Signature]	SCALE 1/16" = 1"	FULL	APPROVAL [Signature]	
DIMENSIONS IN INCHES	NOTICE RE PROPRIETARY INFORMATION: This drawing and the information contained herein are the proprietary property of Moore Industries International, Inc. (MII) and should not be reproduced or disclosed to any third party without the written consent of an authorized officer of MII.				

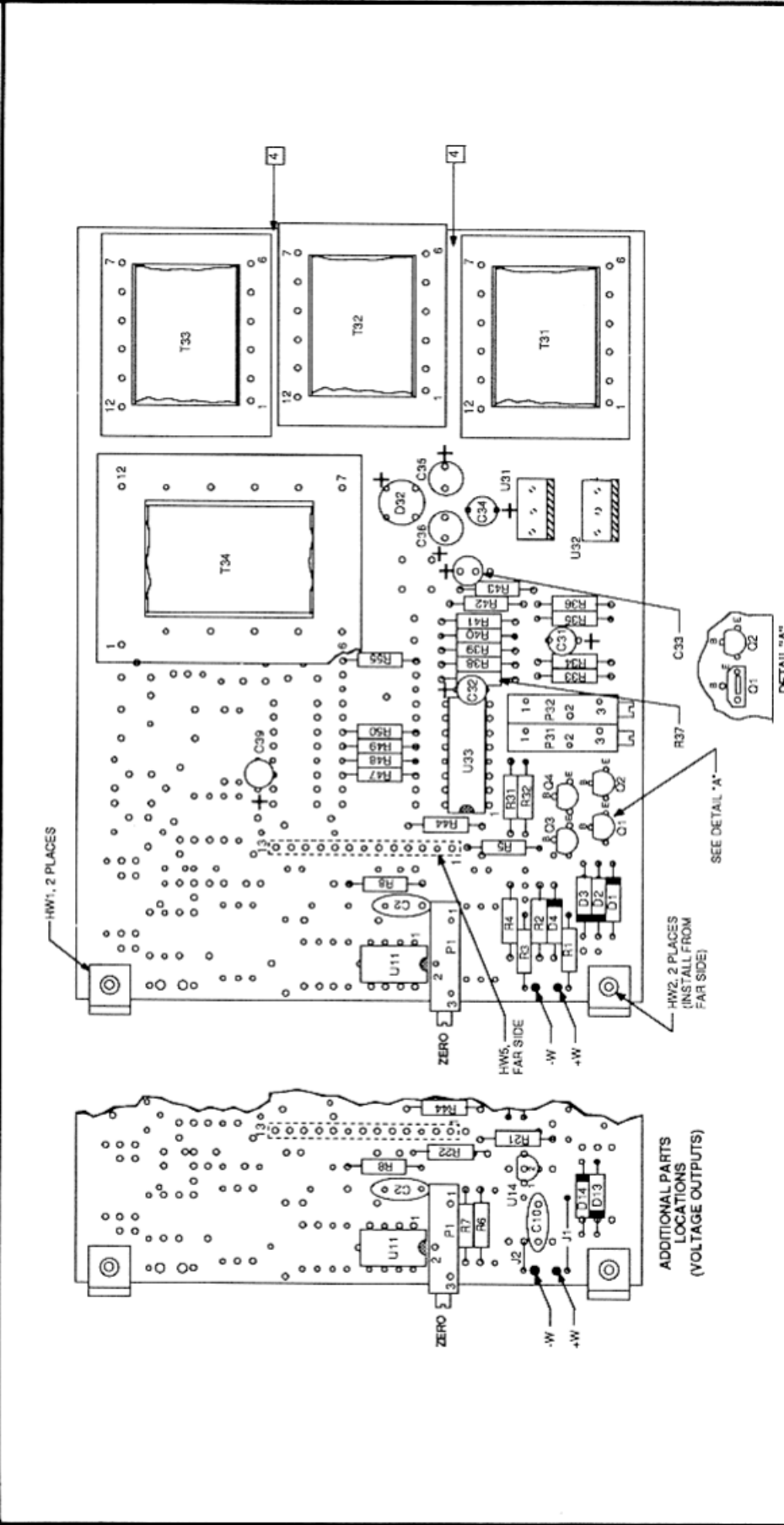

- HW1, 2 PLACES
 HW2, 2 PLACES (INSTALL FROM FAR SIDE)
 SEE DETAIL "A"
 DETAIL "A"
 OPTIONAL Q1 FOR 4-20 MA UNITS ONLY
- ADDITIONAL PARTS LOCATIONS (VOLTAGE OUTPUTS)**
1. CUT OFF PINS OF T32 FACING T31 AND PINS OF T33 FACING T32.
 2. INSTALL P1 POT FLAT ON BOARD.
 3. ALL LEADS MUST BE SOLDERED TO PADS.
- NOTES : ALL JUMPERS ARE 22 AWG BUS, TEFLON SLEEVED AS REQUIRED. UNLESS OTHERWISE SPECIFIED.

RETURN PROCEDURES

To return equipment to Moore Industries for repair, follow these four steps:

1. Call Moore Industries and request a Returned Material Authorization (RMA) number.

Warranty Repair –

If you are unsure if your unit is still under warranty, we can use the unit's serial number to verify the warranty status for you over the phone. Be sure to include the RMA number on all documentation.

Non-Warranty Repair –

If your unit is out of warranty, be prepared to give us a Purchase Order number when you call. In most cases, we will be able to quote you the repair costs at that time. The repair price you are quoted will be a "Not To Exceed" price, which means that the actual repair costs may be less than the quote. Be sure to include the RMA number on all documentation.

2. Provide us with the following documentation:
 - a) A note listing the symptoms that indicate the unit needs repair
 - b) Complete shipping information for return of the equipment after repair
 - c) The name and phone number of the person to contact if questions arise at the factory
3. Use sufficient packing material and carefully pack the equipment in a sturdy shipping container.
4. Ship the equipment to the Moore Industries location nearest you.

The returned equipment will be inspected and tested at the factory. A Moore Industries representative will contact the person designated on your documentation if more information is needed. The repaired equipment, or its replacement, will be returned to you in accordance with the shipping instructions furnished in your documentation.

WARRANTY DISCLAIMER

THE COMPANY MAKES NO EXPRESS, IMPLIED OR STATUTORY WARRANTIES (INCLUDING ANY WARRANTY OF MERCHANTABILITY OR OF FITNESS FOR A PARTICULAR PURPOSE) WITH RESPECT TO ANY GOODS OR SERVICES SOLD BY THE COMPANY. THE COMPANY DISCLAIMS ALL WARRANTIES ARISING FROM ANY COURSE OF DEALING OR TRADE USAGE, AND ANY BUYER OF GOODS OR SERVICES FROM THE COMPANY ACKNOWLEDGES THAT THERE ARE NO WARRANTIES IMPLIED BY CUSTOM OR USAGE IN THE TRADE OF THE BUYER AND OF THE COMPANY, AND THAT ANY PRIOR DEALINGS OF THE BUYER WITH THE COMPANY DO NOT IMPLY THAT THE COMPANY WARRANTS THE GOODS OR SERVICES IN ANY WAY.

ANY BUYER OF GOODS OR SERVICES FROM THE COMPANY AGREES WITH THE COMPANY THAT THE SOLE AND EXCLUSIVE REMEDIES FOR BREACH OF ANY WARRANTY CONCERNING THE GOODS OR SERVICES SHALL BE FOR THE COMPANY, AT ITS OPTION, TO REPAIR OR REPLACE THE GOODS OR SERVICES OR REFUND THE PURCHASE PRICE. THE COMPANY SHALL IN NO EVENT BE LIABLE FOR ANY CONSEQUENTIAL OR INCIDENTAL DAMAGES EVEN IF THE COMPANY FAILS IN ANY ATTEMPT TO REMEDY DEFECTS IN THE GOODS OR SERVICES. BUT IN SUCH CASE THE BUYER SHALL BE ENTITLED TO NO MORE THAN A REFUND OF ALL MONIES PAID TO THE COMPANY BY THE BUYER FOR PURCHASE OF THE GOODS OR SERVICES.

ANY CAUSE OF ACTION FOR BREACH OF ANY WARRANTY BY THE COMPANY SHALL BE BARRED UNLESS THE COMPANY RECEIVES FROM THE BUYER A WRITTEN NOTICE OF THE ALLEGED DEFECT OR BREACH WITHIN TEN DAYS FROM THE EARLIEST DATE ON WHICH THE BUYER COULD REASONABLY HAVE DISCOVERED THE ALLEGED DEFECT OR BREACH, AND NO ACTION FOR THE BREACH OF ANY WARRANTY SHALL BE COMMENCED BY THE BUYER ANY LATER THAN TWELVE MONTHS FROM THE EARLIEST DATE ON WHICH THE BUYER COULD REASONABLY HAVE DISCOVERED THE ALLEGED DEFECT OR BREACH.

RETURN POLICY

For a period of thirty-six (36) months from the date of shipment, and under normal conditions of use and service, Moore Industries ("The Company") will at its option replace, repair or refund the purchase price for any of its manufactured products found, upon return to the Company (transportation charges prepaid and otherwise in accordance with the return procedures established by The Company), to be defective in material or workmanship. This policy extends to the original Buyer only and not to Buyer's customers or the users of Buyer's products, unless Buyer is an engineering contractor in which case the policy shall extend to Buyer's immediate customer only. This policy shall not apply if the product has been subject to alteration, misuse, accident, neglect or improper application, installation, or operation. THE COMPANY SHALL IN NO EVENT BE LIABLE FOR ANY INCIDENTAL OR CONSEQUENTIAL DAMAGES.



WORLDWIDE • www.miinet.com

United States • info@miinet.com Tel: (818) 894-7111 • FAX: (818) 891-2816	Belgium • info@mooreind.be Tel: 03/448.10.18 • FAX: 03/440.17.97	China • sales@mooreind.sh.cn Tel: 86-21-62491499 • FAX: 86-21-62490635
Australia • sales@mooreind.com.au Tel: (02) 8536-7200 • FAX: (02) 9525-7296	The Netherlands • sales@mooreind.nl Tel: (0)344-617971 • FAX: (0)344-615920	United Kingdom • sales@mooreind.com Tel: 01293 514488 • FAX: 01293 536852